

## 2.0 RIDUTTORE AD ASSI ORTOGONALI **BEVEL HELICAL GEARBOX** **KEGELSTIRNRADGETRIEBE**

2.1	Caratteristiche	<i>Characteristics</i>	Merkmale	10
2.2	Designazione	<i>Designation</i>	Bezeichnung	11
2.3	Sensi di rotazione alberi	<i>Direction of shaft rotation</i>	Drehrichtungen der Wellen	12
2.4	Entrata supplementare	<i>Additional input</i>	Zusatzantrieb	12
2.5	Velocità in entrata	<i>Input speed</i>	Antriebsdrehzahl	13
2.6	Rendimento	<i>Efficiency</i>	Wirkungsgrad	13
2.7	Potenza termica	<i>Thermal power</i>	Thermische Leistung	13
2.8	Dati tecnici	<i>Technical data</i>	Technische Daten	14
2.9	Dimensioni	<i>Dimensions</i>	Abmessungen	16
2.10	Accessori	<i>Accessories</i>	Zubehör	22
2.11	Giochi angolari	<i>Angular backlash</i>	Winkelspiel	27
2.12	Lubrificazione	<i>Lubrication</i>	Schmierung	27
2.13	Carichi radiali e assiali	<i>Radial and axial loads</i>	Radial- und Axialbelastungen	29
2.14	Lista parti di ricambio	<i>Spare parts list</i>	Ersatzteilliste	31

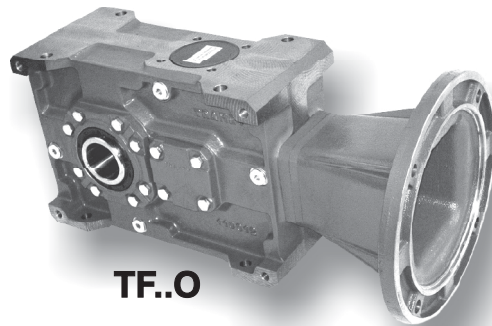

**TF..O**

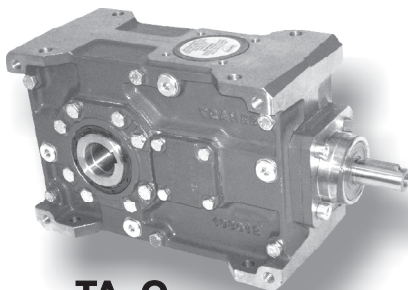

**TA..O**

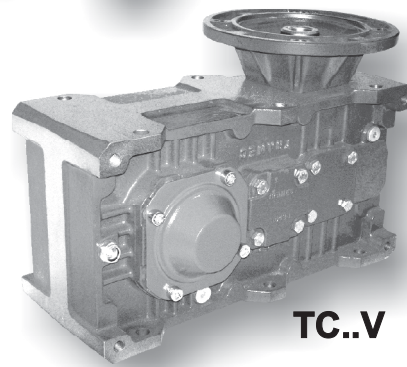

**TC..V**

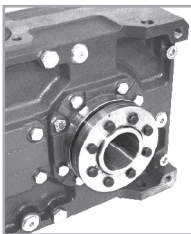

Albero lento cavo con calettatore  
*Hollow output shaft with shrink disc*  
Abtriebshohlwelle mit Schrumpfscheibe

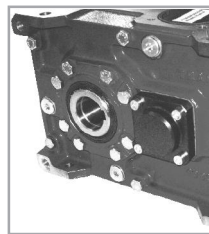

Dispositivo antiretro  
*Backstop device*  
Rücklaufperre

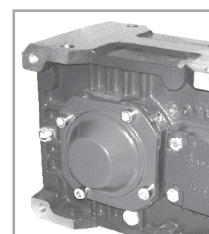

Kit protezione albero cavo  
*Hollow shaft protection kit*  
Schutzvorrichtung für die Hohlwelle

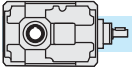

## 2.1 Caratteristiche

- Costruiti in 9 grandezze a 2 riduzioni e in 8 grandezze a 3 riduzioni.
- Sono previsti tre tipi di entrata: con albero entrata sporgente, con predisposizione attacco motore (campana e giunto) e predisposizione attacco motore COMPATTA, escluse grandezze 56 e 63. I tre tipi di entrata possono essere montati indifferentemente nelle esecuzioni verticale e/o orizzontale.
- Il corpo riduttore in lega di alluminio, GAISI9Cu1 UNI7369/3 (56-63), in ghisa meccanica EN GJL 200 UNI EN 1561 (71-180) o in ghisa sferoidale EN GJS 400-15U UNI EN1563 (200-225), abbondantemente nervato all'interno e all'esterno per garantire la rigidità, è lavorato su tutti i piani per consentire un facile posizionamento; inoltre un'unica camera di lubrificazione garantisce una maggiore dissipazione termica e una migliore lubrificazione di tutti gli organi interni.
- Gli ingranaggi sono costruiti in acciaio legato da cementazione e sottoposti a trattamento di cementazione a tempra. In particolare, la prima riduzione è costituita da due ingranaggi conici a dentatura spirale GLEASON con profilo accuratamente rodato, in acciaio 16CrNi4 o 18NiCrMo5 UNI7846 cementati e temprati.
- L'utilizzo dei cuscinetti a rulli conici di qualità su tutti gli assi (ad eccezione del manico in entrata nella predisposizione attacco motore compatta, il quale è sostenuto da cuscinetti obliqui a sfere) consente al riduttore di ottenere delle durate molto elevate e di sopportare dei carichi radiali e assiali esterni molto elevati.
- L'albero lento cavo di serie in acciaio (disponibile a richiesta con calettatore), la possibilità di montare una flangia uscita su uno o entrambi i fianchi laterali e la predisposizione per il montaggio del dispositivo antirivolo esaltano la versatilità di questi riduttori facilitandone l'installazione.
- Il corpo riduttore, le flange, le campane ed i coperchi vengono verniciati esternamente di colore BLU RAL 5010, ad eccezione dei riduttori ortogonali delle grandezze 56 e 63, realizzati in alluminio.

## 2.1 Characteristics

- *Built in 9 sizes with 2 reduction stages and in 8 sizes with 3 reduction stages .*
- *Three input types are available : projecting input shaft, pre-engineered motor coupling (bell and joint) and pre-engineered COMPACT motor coupling. (Sizes 56 and 63 excluded). the three input types can be mounted either vertically and/or horizontally.*
- *Gear unit casing in aluminium alloy GAISI9Cu1 UNI7369/3 (56-63), in engineering cast iron, EN GJL 200 UNI EN 1561 (71-180) or spheroidal graphite cast iron EN GJS 400-15 U UNI EN 1563 (200-225), it is ribbed internally and externally to guarantee rigidity. It is machined on all surfaces for easy positioning. The single lubrication chamber guarantees improved heat dissipation and improved lubrication of all the internal components.*
- *Gears are built in casehardened compound steel and have undergone case-hardening and quench-hardening treatments. In particular, the first reduction stage consists of two GLEASON spiral bevel gears with precision ground profile, in 16CrNi4 or 18NiCrMo5 UNI7846 case-hardened and quench-hardened steel.*
- *The use of high-quality tapered roller bearings on all shafts (except for the input sleeve on the pre-engineered compact motor coupling, which is supported by angular ball bearings) ensures long life and enables very high external radial and axial loads.*
- *The standard hollow output shaft made of steel (shrink disc available on request), the option of mounting an output flange on one or both sides and the possibility of mounting a backstop device make these gear units extremely versatile and easy to install.*
- *Gearbox housing, flanges, bells and covers are externally painted with BLUE RAL 5010, except for bevel helical gearboxes size 56 and size 63 which are made in aluminium.*

## 2.1 Merkmale

- Erhältlich in 9 Größen zu je 2 Untersetzungsstufen und in 8 Größen zu je 3 Untersetzungsstufen.
- Vorgesehen sind drei Antriebsarten: mit vorstehender Antriebswelle, mit Auslegung für Motoranschluß (Glocke und Kupplung), mit Kompaktauslegung für Motoranschluß (Größe 56 und 63 Ausgenommen). Die drei Antriebstoppen können alle sowohl bei der vertikalen als auch der horizontalen Ausführung verwendet werden.
- Das Getriebegehäuse ist aus Aluminiumlegierung GAISI9Cu1 UNI7369/3 (56-63), Maschinenguß EN GJL 200 UNI EN 1561 (71-180) oder aus Sphäroguß EN GJS 400-15 U UNI EN 1563 (200-225) und mit Rippen versehen, die Starrheit gewährleisten; die Bearbeitung aller Flächen ermöglicht eine leichte Positionierung; eine einzige Schmierkammer gewährleistet eine höhere Wärmedissipation und eine bessere Schmierung aller inneren Elemente.
- Die Zahnräder bestehen aus legiertem Einsatzstahl, sie wurden einsatz- und abschreckgehärtet. Insbesondere, die erste Untersetzungsstufe besteht aus zwei spiralverzahnten GLEASON-Kegelrädern mit sorgfältig geschliffenen Profil aus einsatz- und abschreckgehärtetem 16CrNi4- oder 18NiCrMo5-Stahl UNI7846.
- An allen Achsen wurden Qualitäts- Kegelrollenlager verwendet (Ausnahme: Muffe am Antrieb bei Kompaktauslegung, diese wird von Schrägkugellagern gehalten); diese gewährleisten eine hohe Lebensdauer und das Aushalten von sehr hoher Radial- und Axialbelastungen.
- Die serienmäßige Abtriebshohlwelle aus Stahl (auf Wunsch mit Schrumpfscheibe erhältlich), die Möglichkeit der Montage eines Abtriebsflansches an einer oder an beiden Seiten und die Auslegung für die Montage der Rücklaufsperrung heben die Vielseitigkeit dieser Untersetzungsgetriebe hervor und erleichtern ihren Einbau.
- Getriebegehäuse, Flansche, Glocken und Deckel werden mit BLAU RAL 5010 lackiert (mit Ausnahme von Kegelstirnradgetriebe Größe 56 und 63, die aus Aluminium bestehen).

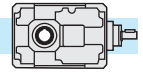

2.2 Designazione

2.2 Designation

2.2 Bezeichnung

Macchina Machine Maschine	Tipo entrata Input type Antriebsart	Grandezza Size Größe	Rotismo Gearing Räderwerk	Rapporto rid. Ratio Untersetzungsverhältnis	Predisposiz. Motor coupling Motorschluss	Esecuzione Execution Ausführung	Posizione di montaggio Mounting position Baulage	Flangia uscita Output flange Abtriebsflansch	Antintorno Back-stop device Rücklaufsperr	Calentatore Shrink disk Schrumpfscheibe	Entrata supplementare Additional input Zusatzantrieb
T	A	112	B	10/1	P.A.M.	O	B3	FLS	CW	C.S.	S.e.A.
Riduttore ad assi ortogonali Bevel helical gearbox Kegelstirnradgetriebe	A	56 63 71 90 112 140 180 200 225	B	in = .../1 5 ÷ 630	56÷225	O	B3 B6 B7 B8 VA VB	FLS	AW	C.S.	A
	C	56 63 80 100 125 160 180 200	C			V		FLD	CW	C.D.	C
	F		F					2FL			F

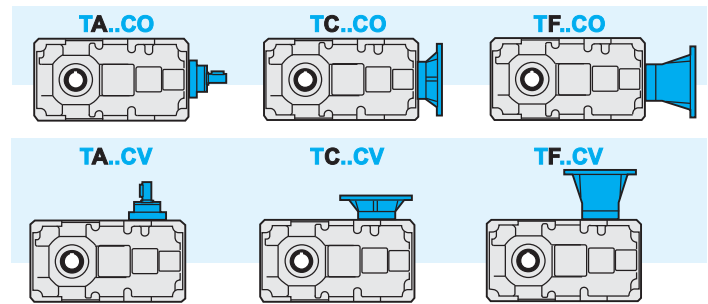
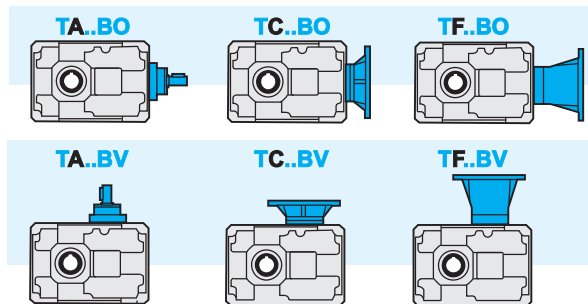

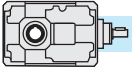

### 2.3 Sensi di rotazione alberi

Nei riduttori esecuzione orizzontale, per ottenere il senso di rotazione contrario al catalogo dell' albero lento mantenendo invariato il senso di rotazione dell' albero veloce, è sufficiente ruotare il riduttore di 180° attorno all' asse dell'albero veloce, utilizzando in pratica il piano di fissaggio opposto.

Nei riduttori esecuzione verticale è possibile fornire il senso di rotazione contrario al catalogo specificandolo al momento dell' ordine.

### 2.3 Direction of shaft rotation

*With regard to horizontal mounted gearboxes, in order to get output rotation in a direction opposite to that given in the catalogue, nevertheless keeping input rotation direction unchanged, simply turn the gearbox 180° around the input shaft; in practice, mount the other way up.*

*Vertical units can be supplied with rotation direction opposite to that given in the catalogue; specify when ordering.*

### 2.3 Drehrichtungen der Wellen

Wenn bei Untersetzungsgetrieben in waagerechter Ausführung für die Abtriebswelle eine andere als die im Katalog angegebene Drehrichtung gewünscht wird und die Antriebswelle ihre Drehrichtung beibehalten soll, so genügt es, das Getriebe um 180° um die Achse der Antriebswelle zu drehen, d.h. die gegenüberliegende Anschlußfläche zu verwenden.

Untersetzungsgetrieben in vertikaler Ausführung sind mit gegensätzlicher Drehrichtung lieferbar, deswegen ist es bei der Bestellung anzugeben, falls die umgekehrte Drehrichtung gewünscht wird.

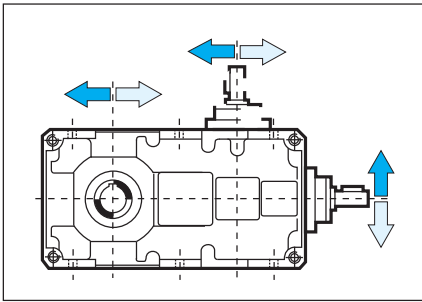

**Sensi di rotazione standard  
Standard direction of rotation  
Standarddrehrichtungen.**

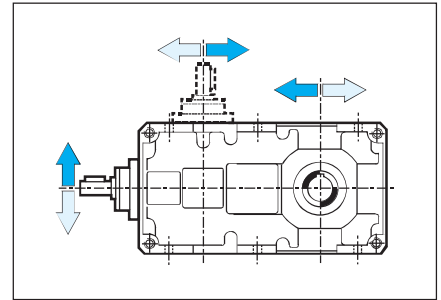

### 2.4 Entrata supplementare

La lavorazione del corpo prevede la possibilità di montare indifferentemente l'albero entrata nella posizione orizzontale (O) o verticale (V) per tutte le grandezze dei riduttori escludendo la grandezza 56 e la 63. Il cambio di versione può essere facilmente realizzato anche successivamente al primo montaggio.

Fatta esclusione per le grandezze 56 e 63, esiste la possibilità di montare la seconda entrata scegliendola, in base alle necessità, tra quelle previste: TA, TC, TF.

In questo caso occorre definire la versione del riduttore con l'entrata principale e specificare quindi la seconda entrata.

### 2.4 Additional input

*The input shaft can be mounted either horizontally (O) or vertically (V) on all sizes except for 56 and 63. The version can be easily changed even after the first assembly.*

*Except for sizes 56 and 63, there is the possibility of mounting a second input; the available options are TA, TC, TF.*

*Both the main input and the additional second input shall be specified when ordering.*

### 2.4 Zusatzantrieb

Die Antriebswelle kann entweder waagrecht (O) oder senkrecht (V) montiert werden (Größe 56 und 63 Ausgenommen). Auch nach der ersten Montage kann die Version leicht geändert werden. Mit Ausnahme von den Größen 56 und 63 kann eine zweite Antrieb TA, TC oder TF montiert werden.

Bei der Bestellung sollen sowohl die hauptsächliche Antrieb als auch die zweite Antrieb angegeben werden.

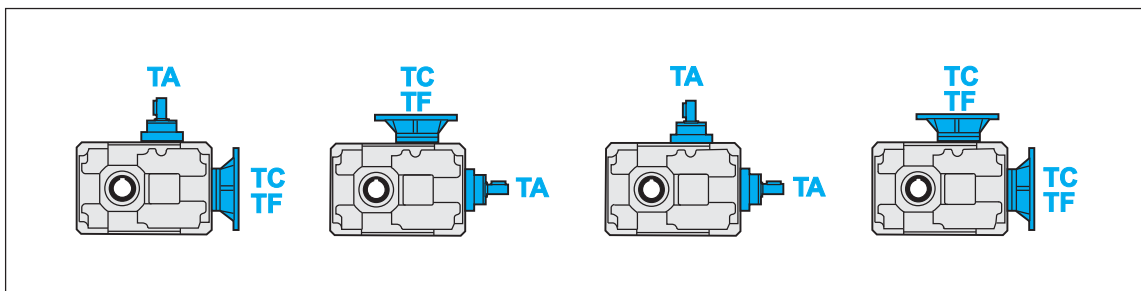

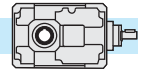

## 2.5 Velocità in entrata

Tutte le prestazioni dei riduttori sono calcolate in base ad una velocità in entrata di  $1400 \text{ min}^{-1}$ .

Tutti i riduttori ammettono velocità fino a  $3000 \text{ min}^{-1}$  anche se è consigliabile, dove l'applicazione lo permette, utilizzare valori inferiori a  $1400 \text{ min}^{-1}$ .

Nella tabella sottostante riportiamo i coefficienti correttivi della potenza in entrata P alle varie velocità riferita ad  $F_s = 1$

Tab. 1

$n_1$ (rpm)	3000	2800	2200	1800	1400	900	700	500
Pc (kW)	P x 1.9	P x 1.8	P x 1.48	P x 1.24	P x 1	P x 0.7	P x 0.56	P x 0.42

## 2.6 Rendimento

Il valore del rendimento dei riduttori può essere stimato con sufficiente approssimazione in base al numero di riduzioni, trascurando le variazioni non significative attribuibili alle varie grandezze e rapporti.

## 2.5 Input speed

All calculations of gear unit performance are based on an input speed of  $1400 \text{ min}^{-1}$ .

All gear units permit speed up to  $3000 \text{ min}^{-1}$ , nevertheless it is advisable to keep below  $1400 \text{ min}^{-1}$ , depending on application.

The table below reports input power P corrective coefficients at the various speeds, with  $F_s = 1$ .

## 2.6 Efficiency

The efficiency value of the gear units can be estimated sufficiently well on the basis of the number of reduction stages, ignoring non-significant variations which can be attributed to the various sizes and ratios.

$\eta$	T...B	T...C
	0.95	0.93

## 2.7 Potenza termica

I valori delle potenze termiche,  $P_{T0}$  (kW), relative alle diverse grandezze di riduttori ortogonali sono riportati nella tabella seguente in funzione della velocità di rotazione in entrata del riduttore

## 2.7 Thermal power

The following table shows the values of thermal power  $P_{T0}$  (kW) for each gearbox size on the basis of rotation speed at gearbox input.

Tab. 2

T	Potenza Termica / Thermal power / Thermische Leistung $P_{T0}$ [kW]	
	$n_1$ [ $\text{min}^{-1}$ ]	
	1400	2800
T56B	4.0	3.4
T63B	5.5	4.7
TA71B	4.4	3.8
TA90B	6.7	5.7
TA112B	10.1	8.6
TA140B	15.2	12.9
TA180B	24.6	20.9
TA200B	31.5	26.8
TA225B	39.9	33.9
T56C	3.3	2.8
T63C	4.2	3.6
TA80C	5.0	4.3
TA100C	7.6	6.5
TA125C	11.5	9.8
TA160C	18.3	15.6
TA180C	22.9	19.4
TA200C	29.9	25.4

## 2.5 Antriebsdrehzahl

Bei der Berechnung der Getriebeleistungen wurde eine Antriebsdrehzahl von  $1400 \text{ min}^{-1}$  berücksichtigt.

Bei allen Getriebensind Antriebsdrehzahlen bis  $3000 \text{ min}^{-1}$  möglich; es ist jedoch ratsam, die Drehzahlen unter  $1400 \text{ min}^{-1}$  zu halten, wenn die Anwendung es ermöglicht.

In der folgenden Tabelle finden Sie die Korrektorkoeffizienten für die Antriebsleistung P bei den verschiedenen Drehzahlen, bezogen auf  $F_s = 1$ .

## 2.6 Wirkungsgrad

Der Wirkungsgrad der Getriebe kann mit ausreichender Annäherung aufgrund der Anzahl der Untersetzungsstufen ermittelt werden, dabei können die unwesentlichen Veränderungen, die auf die verschiedenen Größen und Untersetzungsverhältnisse zurückzuführen sind, außer acht gelassen werden.

## 2.7 Thermische Leistung

Die folgende Tabelle enthält die Werte  $P_{T0}$  der thermischen Leistung (kW) je nach Getriebegröße und abhängig von Drehzahlen am Getriebeantrieb.

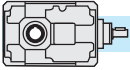

2.8 Dati tecnici

2.8 Technical data

2.8 Technische Daten

T	n <sub>1</sub> = 1400			TC - TF				TA	
	in	ir	n <sub>2</sub> rpm	T <sub>2</sub> Nm	P <sub>1</sub> kW	FS'	IEC	T <sub>2M</sub> Nm	P kW
56B	8	8.06	174	94	1.8	1.2		110	2.1
	10	10.17	138	119	1.8	1.0	56	120	1.8
	12.5	12.31	114	120	1.5	1.1	63 (B5)	130	1.6
	16	15.00	93	107	1.1	1.3	71	140	1.4
	20	20.33	69	119	0.9	1.2	80	140	1.1
	25	24.62	57	120	0.75	1.2	90 (B5)	140	0.90
	31.5	30.00	47	107	0.55	1.3	(B14)	140	0.70
	40	39.38	36	140	0.55	1.0	TF	140	0.55
	50	48.00	29	115	0.37	1.2		140	0.45
56C	40	40.28	35	95	0.37	1.4		135	0.53
	50	50.83	28	119	0.37	1.2	56	140	0.43
	63	61.54	23	98	0.25	1.4	63 (B5)	140	0.36
	80	75.00	19	119	0.25	1.2	71	145	0.30
	100	101.67	14	116	0.18	1.2	80	145	0.22
	125	123.08	11	141	0.18	1.0	90 (B5)	145	0.19
	160	150.00	9	124	0.13	1.2	(B14)	145	0.15
	200	196.92	7	112	0.09	1.3	TF	145	0.10
	250	240.00	6	137	0.09	1.1		150	0.10
63B	8	7.94	176	93	1.8	1.7		155	3.0
	10	10.18	138	119	1.8	1.4	56	170	2.6
	12.5	12.50	112	146	1.8	1.3	63 (B5)	185	2.3
	16	15.88	88	185	1.8	1.1	71	200	1.9
	20	20.36	69	198	1.5	1.0	80	200	1.5
	25	25.00	56	178	1.1	1.1	90 (B5)	200	1.2
	31.5	31.00	45	181	0.9	1.1	(B14)	200	1.0
	40	40.00	35	194	0.75	1.0	TF	200	0.80
	50	49.60	28	177	0.55	1.1		200	0.60
63	60.80	23	146	0.37	1.2		170	0.40	
63C	40	39.71	35	189	0.75	1.1		200	0.79
	50	50.89	28	178	0.55	1.2	56	210	0.65
	63	62.50	22	147	0.37	1.4	63 (B5)	210	0.53
	80	79.41	18	186	0.37	1.1	71	210	0.42
	100	101.79	14	161	0.25	1.3	80	210	0.33
	125	125.00	11	198	0.25	1.1	90 (B5)	210	0.26
	160	155.00	9	177	0.18	1.2	(B14)	210	0.21
	200	200.00	7	165	0.13	1.3	TF	210	0.17
	250	248.00	6	205	0.13	1.0		210	0.13
315	304.00	5	174	0.09	1.0		180	0.09	
71B	10	10.25	137	120	1.8	1.9		230	3.5
	12.5	13.05	107	152	1.8	1.6	63	240	2.8
	16	15.63	90	182	1.8	1.4	71	250	2.5
	20	19.64	71	229	1.8	1.3	80	250	2.3
	25	24.99	56	243	1.5	1.2	90 (B5)	280	1.7
	31.5	29.95	47	213	1.1	1.2	TC-TF	260	1.3
	40	38.73	36	226	0.9	1.1	80	240	1.0
	50	50.18	28	244	0.75	1.1	(B14)	260	0.80
	63	60.13	23	214	0.55	1.2	TC	260	0.70
80	77.76	18	186	0.37	1.3		240	0.50	

T	n <sub>1</sub> = 1400			TC - TF				TA	
	in	ir	n <sub>2</sub> rpm	T <sub>2</sub> Nm	P <sub>1</sub> kW	FS'	IEC	T <sub>2M</sub> Nm	P kW
90B	5*	4.56	307	118	4	3.2		380	12.8
	6.3*	6.26	224	162	4	2.5		405	10.0
	10	10.25	137	266	4	1.8	71	480	7.2
	12.5	13.05	107	338	4	1.6	80	480	7.2
	16	15.63	90	405	4	1.4	90	530	6.3
	20	19.64	71	509	4	1.2	100	550	5.4
	25	24.99	56	486	3	1.3	112 (B5)	620	4.9
	31.5	29.95	47	427	2.2	1.3	TC-TF	630	3.9
	40	38.73	36	452	1.8	1.1	90*	560	2.9
	50	50.18	28	488	1.5	1.1	(B14)	500	2.0
	63	60.13	23	429	1.1	1.3	TC	550	1.7
	80	77.76	18	454	0.9	1.1		570	1.5
80C	50	52.18	27	596	1.8	1.1		660	2.0
	63	62.53	22	595	1.5	1.1		680	1.7
	80	79.58	18	555	1.1	1.3	63	710	1.4
	100	99.97	14	698	1.1	1.1	71	740	1.2
	125	119.78	12	684	0.9	1.1	80	740	1.0
	160	152.45	9	532	0.55	1.3	90 (B5)	680	0.70
	200	182.67	8	637	0.55	1.1	TC-TF	700	0.60
	250	240.51	6	565	0.37	1.3	80	750	0.49
	315	306.11	5	719	0.37	1.0	(B14)	740	0.38
	400	366.78	4	582	0.25	1.2	TC	700	0.30
	500	474.35	3	542	0.18	1.2		660	0.22
	630	613.46	2	506	0.13	1.2		620	0.16
112B	5*	4.86	288	290	9.2	1.5		440	14.0
	10	10.25	137	611	9.2	1.5		920	13.9
	12.5	13.05	107	778	9.2	1.3		1000	11.8
	16	15.63	90	932	9.2	1.2	80	1100	10.9
	20	19.64	71	1171	9.2	1.0	90	1190	9.4
	25	24.99	56	1215	7.5	1.1	100	1190	9.4
	31.5	29.95	47	1067	5.5	1.1	112	1280	7.9
	40	38.73	36	1004	4	1.0	132 (B5)	1220	6.3
	50	50.18	28	976	3	1.1	TC-TF	1050	4.2
	63	60.13	23	857	2.2	1.4		1070	3.3
	80	77.76	18	907	1.8	1.2		1240	3.2
	1080							1080	2.1
100C	50	52.18	27	993	3	1.3		1300	3.9
	63	62.53	22	1190	3	1.1	71	1350	3.4
	80	79.58	18	1111	2.2	1.3	80	1410	2.8
	100	99.97	14	1395	2.2	1.1	90	1470	2.3
	125	119.78	12	1368	1.8	1.1	100	1480	1.9
	160	152.45	9	1064	1.1	1.3	112 (B5)	1360	1.4
	200	182.67	8	1275	1.1	1.1	TC-TF	1400	1.2
	250	240.51	6	1144	0.75	1.3		1500	1.0
	315	306.11	5	1456	0.75	1.0	90*	1480	0.80
	400	366.78	4	1280	0.55	1.1	(B14)	1400	0.60
	500	474.35	3	1113	0.37	1.2	TC	1360	0.50
	630	613.46	2	973	0.25	1.3		1240	0.30

• Flange quadrate / Square flanges / Viereckige Flansche

\* Rapporti speciali / Special ratios / Sonderverhältnisse

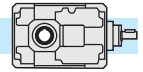

2.8 Dati tecnici

2.8 Technical data

2.8 Technische Daten

T	n <sub>1</sub> = 1400			TC - TF				TA		
	in	ir	n <sub>2</sub> rpm	T <sub>2</sub> Nm	P <sub>1</sub> kW	FS'	IEC	T <sub>2M</sub> Nm	P kW	
140B	7*	6.88	203	983	22	1.4		1350	30.2	
	10	10.25	137	1461	22	1.3		1850	27.9	
	12.5	13.05	107	1860	22	1.1		2050	24.3	
	16	15.63	90	1874	18.5	1.2	80	2200	21.7	
	20	19.64	71	2354	18.5	1.0	90	2400	18.9	
	25	24.99	56	2429	15	1.0	100	2540	15.7	
	31.5	29.95	47	2135	11	1.1	112	2300	11.9	
	40	38.73	36	1882	7.5	1.2	132	2210	8.8	
	50	50.18	28	1789	5.5	1.2	160	2120	6.5	
	63	60.13	23	2143	5.5	1.1	180	2350	6.0	
80	77.76	18	2016	4	1.1	(B5)	2250	4.5		
125C	50	52.18	27	2483	7.5	1.1		2650	8.0	
	63	62.53	22	2182	5.5	1.3		2760	7.0	
	80	79.58	18	2777	5.5	1.0		2880	5.7	
	100	99.97	14	2537	4	1.2	80	3000	4.7	
	125	119.78	12	2280	3	1.3	90	3000	4.0	
	160	152.45	9	2128	2.2	1.3	100	2720	2.8	
	200	182.67	8	2549	2.2	1.1	112	2800	2.4	
	250	240.51	6	2746	1.8	1.1	132	3050	2.0	
	315	306.11	5	2913	1.5	1.0	(B5)	2960	1.5	
	400	366.78	4	2560	1.1	1.1	TC-TF	2800	1.2	
180B	10	10.25	137	1993	30	2.0		3900	58.7	
	12.5	13.05	107	2536	30	1.7		4300	50.9	
	16	15.63	90	3039	30	1.5	100	4500	44.4	
	20	19.64	71	3818	30	1.3	112	5100	40.1	
	25	24.99	56	4859	30	1.1	132	5230	32.3	
	31.5	29.95	47	4269	22	1.1	160	4680	24.1	
	40	38.73	36	3764	15	1.1	180	4300	17.1	
	50	50.18	28	3577	11	1.2	200	4300	13.2	
	63	60.13	23	4286	11	1.1	(B5)	4780	12.3	
	80	77.76	18	3779	7.5	1.2	TC-TF	4380	8.7	
160C	50	52.18	27	4966	15	1.0		5130	15.5	
	63	62.53	22	4363	11	1.2		5350	13.5	
	80	79.58	18	4644	9.2	1.2		5570	11.0	
	100	99.97	14	4756	7.5	1.2	80	5800	9.2	
	125	119.78	12	5699	7.5	1.0	90	5800	7.6	
	160	152.45	9	5319	5.5	1.0	100	5470	5.7	
	200	182.67	8	4635	4	1.2	112	5600	4.8	
	250	240.51	6	4577	3	1.3	132	5600	4.8	
	315	306.11	5	5826	3	1.0	160	5890	3.3	
	400	366.78	4	5119	2.2	1.1	180	5920	3.0	
500	474.35	3	4514	1.5	1.2	(B5)	5600	2.4		
630	613.46	2	4281	1.1	1.2	TC-TF	5280	1.8		
									4960	1.3

T	n <sub>1</sub> = 1400			TC - TF				TA		
	in	ir	n <sub>2</sub> rpm	T <sub>2</sub> Nm	P <sub>1</sub> kW	FS'	IEC	T <sub>2M</sub> Nm	P kW	
200B	8	8.14	172	1582	30	3.2		5000	94.8	
	10	10.43	134	2028	30	2.7		5500	81.4	
	12.5	12.60	111	2449	30	2.4		6000	73.5	
	16	15.63	90	3039	30	2.1	112	6500	64.2	
	20	17.65	79	3432	30	2.1	132	7100	62.1	
	25	24.14	58	4692	30	1.5	160	7150	45.7	
	31.5	29.95	47	5822	30	1.2	180	7250	37.4	
	40	33.82	41	6575	30	1.1	200	7300	33.3	
	50	47.93	29	6833	22	1.1	(B5)	7400	23.8	
	63	54.13	26	6489	18.5	1.1	TC-TF	7400	21.1	
180C	50	53.11	26	6234	18.5	1.2		7240	21.5	
	63	63.64	22	6056	15	1.2		7280	18.0	
	80	76.85	18	7313	15	1.0	80	7420	15.2	
	100	99.39	14	6936	11	1.1	90	7500	11.9	
	125	122.88	11	7172	9.2	1.0	100	7500	9.6	
	160	147.23	10	7005	7.5	1.1	112	7550	8.1	
	200	190.41	7	6644	5.5	1.1	132	7600	6.3	
	250	246.73	6	6261	4	1.2	160	7650	4.9	
	315	295.63	5	7502	4	1.0	180	7700	4.1	
	400	382.33	4	7276	3	1.1	(B5)	7950	3.3	
225B	8	8.44	166	2461	45	3.0		7500	137.1	
	10	10.13	138	2955	45	2.8		8300	126.4	
	12.5	12.45	112	3630	45	2.5		9100	112.8	
	16	15.93	88	4644	45	2.2	132	10000	96.9	
	20	19.13	73	5577	45	1.9	160	10700	86.3	
	25	23.49	60	6850	45	1.6	180	11000	72.3	
	31.5	30.29	46	8832	45	1.3	200	11100	56.6	
	40	37.09	38	8892	37	1.2	225	11100	44.9	
	200C	40	42.62	33	8110	30	1.3		10900	40.3
		50	51.18	27	9740	30	1.1		11000	33.9
63		62.86	22	8772	22	1.3	100	11350	28.5	
80		76.97	18	10742	22	1.0	112	11050	22.6	
100		98.04	14	9330	15	1.2	132	11200	18.0	
125		120.41	12	11459	15	1.0	160	11500	15.1	
160		147.45	9	10290	11	1.1	180	11200	12.0	
200		196.87	7	9367	7.5	1.2	200	11400	9.1	
250		241.79	6	11504	7.5	1.0	(B5)	11700	7.6	
315		296.07	5	10330	5.5	1.1	TC-TF	11850	6.3	

• Flange quadrate / Square flanges / Viereckige Flansche

\* Rapporto speciale / Special ratio / Sonderverhältnisse

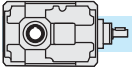

2.9 Dimensioni

2.9 Dimensions

2.9 Abmessungen

	TA... - TF...			
	56B		63B	
R	73.5		75	
F	9		9	
e	45		50	
H h8	65		70	
X h8	65		80	
E h8	65		70	
M	M8		M8	
C f8	70		80	
K	85		100	
L	59		65	
S	71		85	
f	9		9	
m	45		55	
c	73.5		80	
N2	6	8	8	8
M2	22.8	28.3	28.3	31.3
D2 H7	20	25	25	28
b	73.5		75	
r	45		50	
B	92		111	
G	90		100	
V	97		117	
C2	100		120	
F2	9		9	
N1	4		4	
M1	13.8		13.8	
D1h6	12		12	
d1	M4x10		M4x10	
L1	17.5		17.5	
h	113		120.2	
T	—		—	
	TA.. - TF..			
kg	4.5		6.0	

	TA... - TF...			
	56C		63C	
R	73.5		75	
F	9		9	
e	45		50	
H h8	65		70	
X h8	65		80	
E h8	65		70	
M	M8		M8	
C f8	70		80	
K	85		100	
L	94		100	
S	36		50	
f	9		9	
m	45		55	
c	73.5		80	
N2	6	8	8	8
M2	22.8	28.3	28.3	31.3
D2 H7	20	25	25	28
b	73.5		75	
r	45		50	
B	92		111	
G	90		100	
V	97		117	
C2	100		120	
F2	9		9	
N1	4		4	
M1	13.8		13.8	
D1h6	12		12	
d1	M4x10		M4x10	
L1	17.5		17.5	
h	146.6		153.7	
T	229		241.2	
	TA.. - TF..			
kg	5.0		6.5	

IEC..B5	TF...																			
	56B					56C					63B					63C				
	56	63	71	80	90	56	63	71	80	90	56	63	71	80	90	56	63	71	80	90
Y	120	140	160	200	200	120	140	160	200	200	120	140	160	200	200	120	140	160	200	200
P	153	156	163	183	183	187	190	197	217	217	160	163	170	190	190	194	197	201	221	221
Q	218	221	228	248	248	252	255	262	282	282	230	233	240	260	260	264	267	271	291	291
kg	4.5	4.5	4.5	4.5	4.5	5.0	5.0	5.0	5.0	5.0	6.0	6.0	6.0	6.0	6.0	6.5	6.5	6.5	6.5	6.5

IEC..B14	TF...																			
	56B					56C					63B					63C				
	56	63	71	80	90	56	63	71	80	90	56	63	71	80	90	56	63	71	80	90
Y	—	—	105	120	140	—	—	105	120	140	—	—	105	120	140	—	—	105	120	140
P	—	—	163	183	183	—	—	197	217	217	—	—	170	190	190	—	—	204	224	224
Q	—	—	228	248	248	—	—	262	282	282	—	—	240	260	260	—	—	274	294	294
kg	—	—	4.5	4.5	4.5	—	—	5.0	5.0	5.0	—	—	6.0	6.0	6.0	—	—	6.5	6.5	6.5

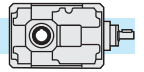

**T..56B - T..56C - T..63B - T..63C**

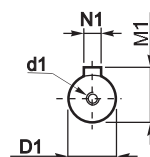
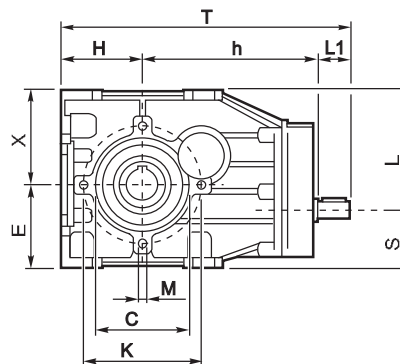
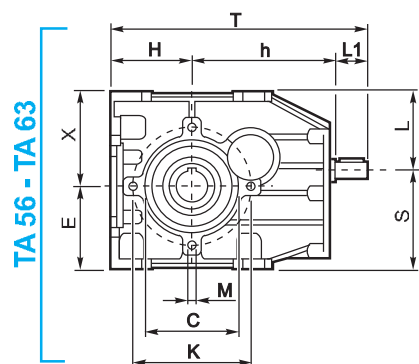
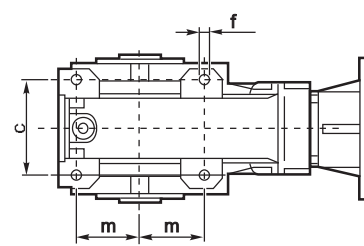
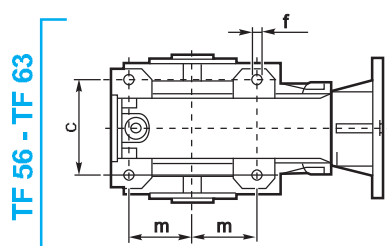
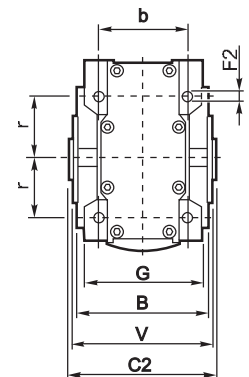
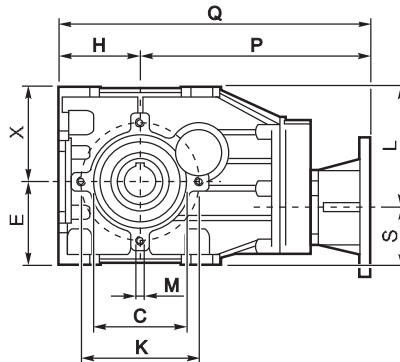
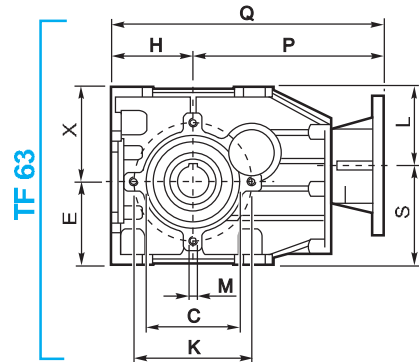
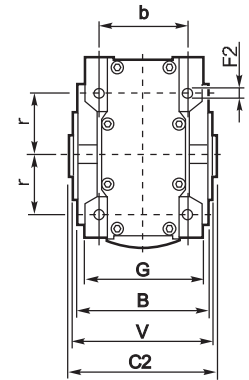
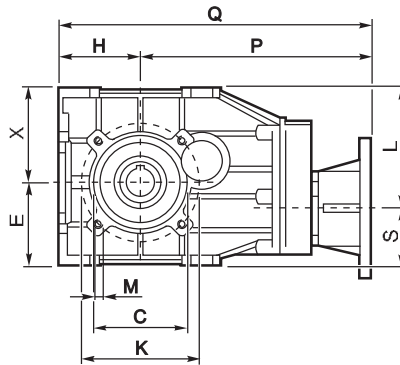
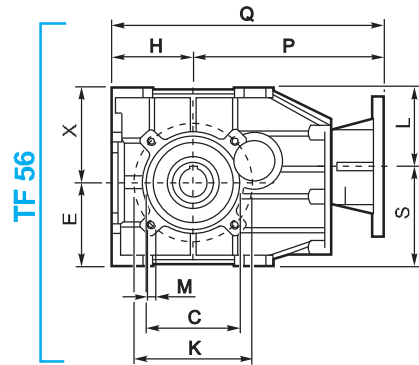
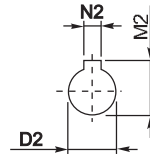
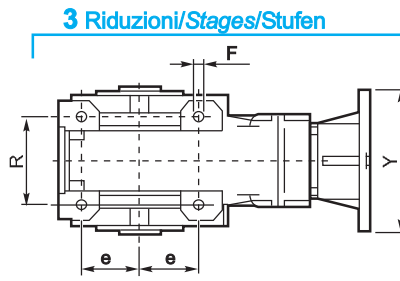
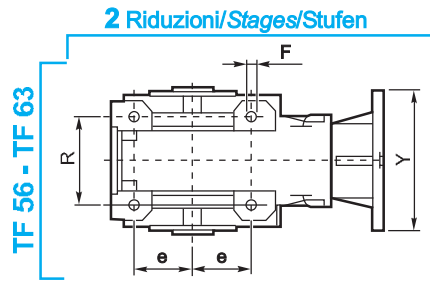

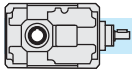

2.9 Dimensioni

2.9 Dimensions

2.9 Abmessungen

	TA... - TC... - TF...															
	71B		90B			112B			140B		180B		200B		225B	
A	142		180			224			280		360		400		450	
a	102		134			166			209		272.5		305		344	
a1	—		—			—			—		—		—		—	
B	112		127			150			175		215		255		290	
b	90		104			125			145		180		210		240	
C2	115		130			155			180		220		260		300	
D1 h6	14		19			24			28		38		38		48	
D2 H7	24	28	32	30	35	42	40	45	55	50	70	60	90	80	100	
E	206		262			326			407		522.5		585		654	
e	38		52			64			82		110		120		140	
F	9		11			13			15		17		19		21	
f	M8x13		M10x16			M12x19			M14x22		M16x25		M18x35		M18x30	
G	122		155			194			244		320		350		400	
g	61		77.5			97			122		160		175		200	
H	71		90			112			140		180		200		225	
h	174		212			262			317		400		422.5		500	
I	110		130			160			190		237.5		237.5		296	
l	125		159.5			199			249		322.5		360		404	
L1	30		40			50			60		80		80		110	
O	64		82			102			127		162.5		185		204	
T	275		342			424			517		660		702.5		835	
t	211		260			322			390		497.5		517.5		631	
Z	9		11			13			15		17		22		25	

TA..							
kg	12.5	20	34	58	116	165	232

TC... - TF...							
kg	15.5	25	44	75	136	185	270

	TC...										
	71B				90B				112B		
IEC	63 B5	71 B5	80/90 B5	80 B14	71 B5	80/90 B5	*90 B14	100/112 B5	80/90 B5	100/112 B5	132 B5
Y	140	160	200	120	160	200	□120 / R73	250	200	250	300
P	177	184	204	204	220	240	240	250	286	296	318
p	113	120	140	140	138	158	158	168	184	194	216
Q	248	255	275	275	310	330	330	340	398	408	430
q	184	191	211	211	228	248	248	258	296	306	328

	140B				180B				200B			
	80/90 B5	100/112 B5	132 B5	160/180 B5	100/112 B5	132 B5	160/180 B5	200 B5	100/112 B5	132 B5	160/180 B5	200 B5
Y	200	250	300	350	250	300	350	400	250	300	350	400
P	331	341	363	393	413(i=10-40) / 423(i=50-80)	463(i=10-40) / 473(i=50-80)	513(i=10-40) / 523(i=50-80)	563(i=10-40) / 573(i=50-80)	435(i=8-40) / 445(i=50-63)	485(i=8-40) / 495(i=50-63)	535(i=8-40) / 545(i=50-63)	585(i=8-40) / 595(i=50-63)
p	204	214	236	266	250(i=10-40) / 260(i=50-80)	300(i=10-40) / 310(i=50-80)	350(i=10-40) / 360(i=50-80)	400(i=10-40) / 410(i=50-80)	250(i=8-40) / 260(i=50-63)	300(i=8-40) / 310(i=50-63)	350(i=8-40) / 360(i=50-63)	400(i=8-40) / 410(i=50-63)
Q	471	481	503	533	593(i=10-40) / 603(i=50-80)	643(i=10-40) / 653(i=50-80)	693(i=10-40) / 703(i=50-80)	743(i=10-40) / 753(i=50-80)	640(i=8-40) / 650(i=50-63)	690(i=8-40) / 700(i=50-63)	740(i=8-40) / 750(i=50-63)	790(i=8-40) / 800(i=50-63)
q	344	354	376	406	430(i=10-40) / 440(i=50-80)	480(i=10-40) / 490(i=50-80)	530(i=10-40) / 540(i=50-80)	580(i=10-40) / 590(i=50-80)	450(i=8-40) / 460(i=50-63)	500(i=8-40) / 510(i=50-63)	550(i=8-40) / 560(i=50-63)	600(i=8-40) / 610(i=50-63)

\* Flange quadrate / Square flanges / Viereckige Flansche

	TF...												
	71B			90B			112B			140B			
IEC	63 B5	71 B5	80/90 B5	71 B5	80/90 B5	100/112 B5	80/90 B5	100/112 B5	132 B5	80/90 B5	100/112 B5	132 B5	160/180 B5
Y	140	160	200	160	200	250	200	250	300	200	250	300	350
P	231	238	259	286	307	317	367	377	398	432	442	463	493
p	167	174	195	204	225	235	265	275	296	305	315	336	366
Q	302	309	330	376	397	407	479	489	510	572	582	603	633
q	238	245	266	294	315	325	377	387	408	445	455	476	506

	180B				200B				225B			
	100/112 B5	132 B5	160/180 B5	200 B5	100/112 B5	132 B5	160/180 B5	200 B5	132 B5	160/180 B5	200 B5	225 B5
Y	250	300	350	400	250	300	350	400	300	350	400	450
P	546	566	596	596	568.5	588.5	618.5	620.5	698	728	728	760
p	393.5	403	433	433	383.5	403.5	433.5	435.5	494	524	524	556
Q	736	746	776	776	768.5	788.5	818.5	820.5	923	953	953	985
q	573.5	583	613	613	583.5	603.5	633.5	635.5	774	749	749	781

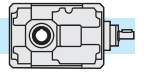

### T..71B - T..225B

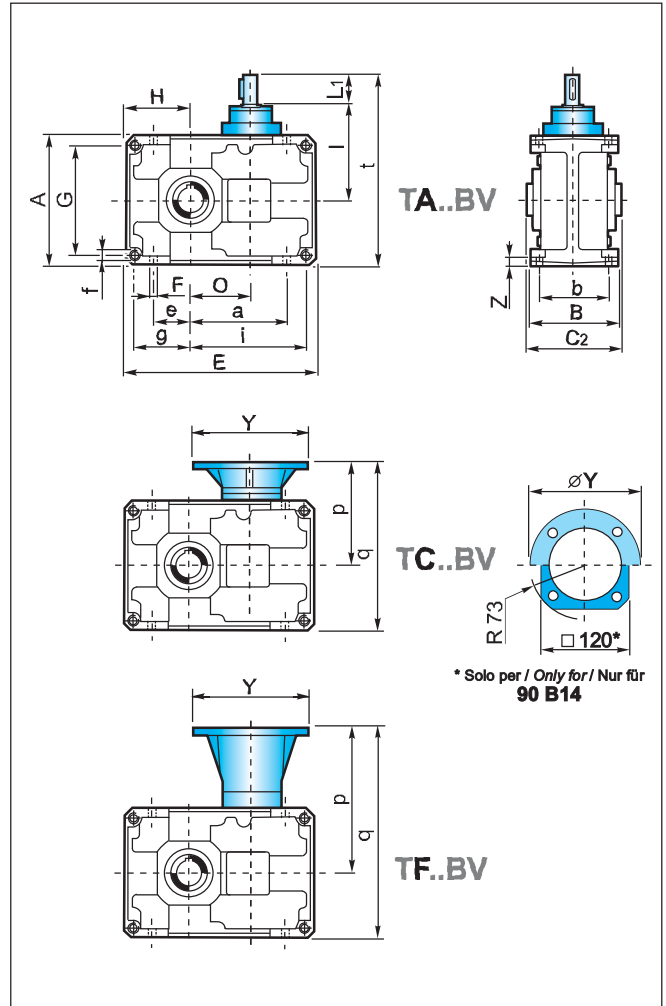
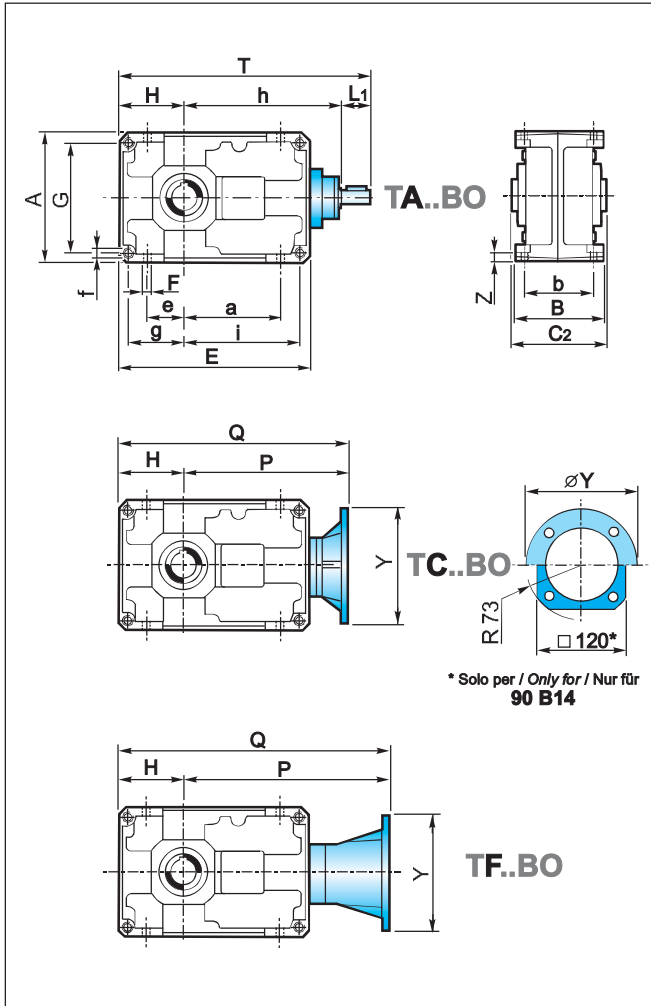

\* Solo per / Only for / Nur für  
90 B14

\* Solo per / Only for / Nur für  
90 B14

**Albero uscita cavo**  
**Hollow output shaft**  
**Abtriebshohlwelle**

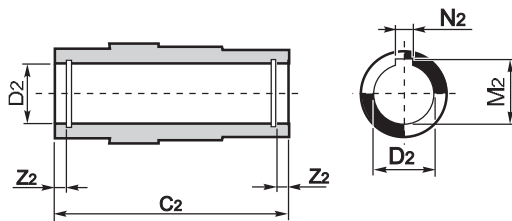

**Albero entrata**  
**Input shaft**  
**Antriebswelle**

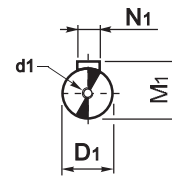

	TA... - TC... - TF...														
	71B		90B			112B			140B		180B		200B		225B
<b>D1 h6</b>	14		19			24			28		38		38		48
<b>d1</b>	M4x15		M8x22			M8x22			M8x22		M10x28		M10x28		M12x34
<b>M1</b>	16		21.5			27			31		41		41		51.5
<b>N1</b>	5		6			8			8		10		10		14
<b>C2</b>	115		130			155			180		220		260		300
<b>D2 H7</b>	24	28	32	30	35	42	40	45	55	50	70	60	90	80	100
<b>M2</b>	27.3	31.3	35.3	33.3	38.3	45.3	43.3	48.8	59.3	53.8	74.9	64.4	95.4	85.4	106.4
<b>N2</b>	8	8	10	8	10	12	12	14	16	14	20	18	25	22	28
<b>Z2</b>	—	—	8.7	8.7	8.4	11	11	11	11.9	11.9	15.4	15.9	18.9	18.9	20

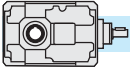

2.9 Dimensioni

2.9 Dimensions

2.9 Abmessungen

	TA... - TC... - TF...												
	80C			100C			125C		160C		180C		200C
A	160			200			250		320		360		400
a	82			102			127		162.5		185		204
a1	106			134			169		217		207		277.5
B	127			150			175		215		255		290
b	104			125			145		180		210		240
C2	130			155			180		220		260		300
D1 h6	14			19			24		28		28		38
D2 H7	32	30	35	42	40	45	55	50	70	60	90	80	100
E	306			384			479		609.5		652		766.5
e	42			52			67		90		100		115
F	11			13			15		17		19		21
f	M10x16			M12x19			M14x22		M16x25		M18x35		M18x30
G	135			170			214		280		310		350
g	67.5			85			107		140		155		175
H	80			100			125		160		180		200
h	256			314			389		479.5		502		604
I	110			130			160		190		190		237.5
i	213.5			269			336		429.5		447		541.5
L1	30			40			50		60		60		80
O	146			184			229		289.5		312		366.5
T	366			454			564		699.5		742		884
t	220			270			335		410		430		517.5
Z	11			13			16		17		22		25

	TA..								
kg	19		36		66		120	170	260

	TC... - TF...						
kg	22	41		76	137	190	295

	TC...										
	80C				100C				125C		
IEC	63 B5	71 B5	80/90 B5	80 B14	71 B5	80/90 B5	*90 B14	100/112 B5	80/90 B5	100/112 B5	132 B5
Y	140	160	200	120	160	200	□120 / R 73	250	200	250	300
P	259	266	286	286	322	342	342	352	413	423	445
p	113	120	140	140	138	158	158	168	184	194	216
Q	339	346	366	366	422	442	442	452	538	548	570
q	193	200	220	220	238	258	258	268	309	319	341

	160C				180C				200C				
	80/90 B5	100/112 B5	132 B5	160 B5	80/90 B5	100/112 B5	132 B5	160/180 B5	100/112 B5		132 B5	160/180 B5	200 B5
IEC	200	250	300	350	200	250	300	350	250		300	350	400
Y	200	250	300	350	200	250	300	350	250		300	350	400
P	493	503	525	555	516	526	548	578	617(l=40-160) / 627(l=200-315)		667(l=40-160) / 677(l=200-315)		
p	204	214	236	266	204	214	236	266	250(l=40-160) / 260(l=200-315)		300(l=40-160) / 310(l=200-315)		
Q	653	663	686	715	696	706	728	758	617(l=40-160) / 627(l=200-315)		867(l=40-160) / 877(l=200-315)		
q	364	374	396	426	384	394	416	446	450(l=40-160) / 460(l=200-315)		500(l=40-160) / 510(l=200-315)		

\* Flange quadrate / Square flanges / Viereckige Flansche

	TF...									
	80C			100C				125C		
IEC	63 B5	71 B5	80/90 B5	71 B5	80/90 B5	100/112 B5	80/90 B5	100/112 B5	132 B5	
Y	140	160	200	160	200	250	200	250	300	
P	313	320	341	388	409	419	494	504	525	
p	167	174	195	204	225	235	265	275	296	
Q	393	400	421	488	509	519	619	629	650	
q	247	254	275	304	325	335	390	400	421	

	160C				180C				200C			
	80/90 B5	100/112 B5	132 B5	160 B5	80/90 B5	100/112 B5	132 B5	160/180 B5	132 B5	160/180 B5	200 B5	
IEC	200	250	300	350	200	250	300	350	300	350	400	
Y	200	250	300	350	200	250	300	350	300	350	400	
P	594	604	625	655	617	627	648	678	770	800	802	
p	305	315	336	366	305	315	336	366	404	434	436	
Q	754	764	785	815	797	807	828	858	970	1000	1002	
q	465	475	496	526	485	495	516	546	604	634	636	

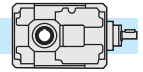

## T..80C - T..200C

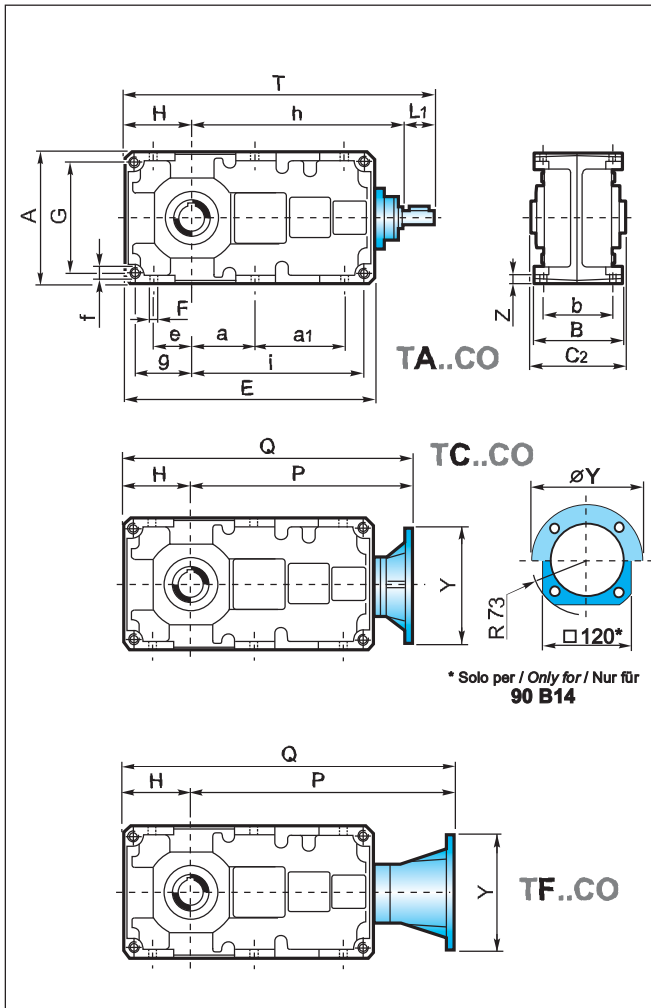

\* Solo per / Only for / Nur für  
90 B14

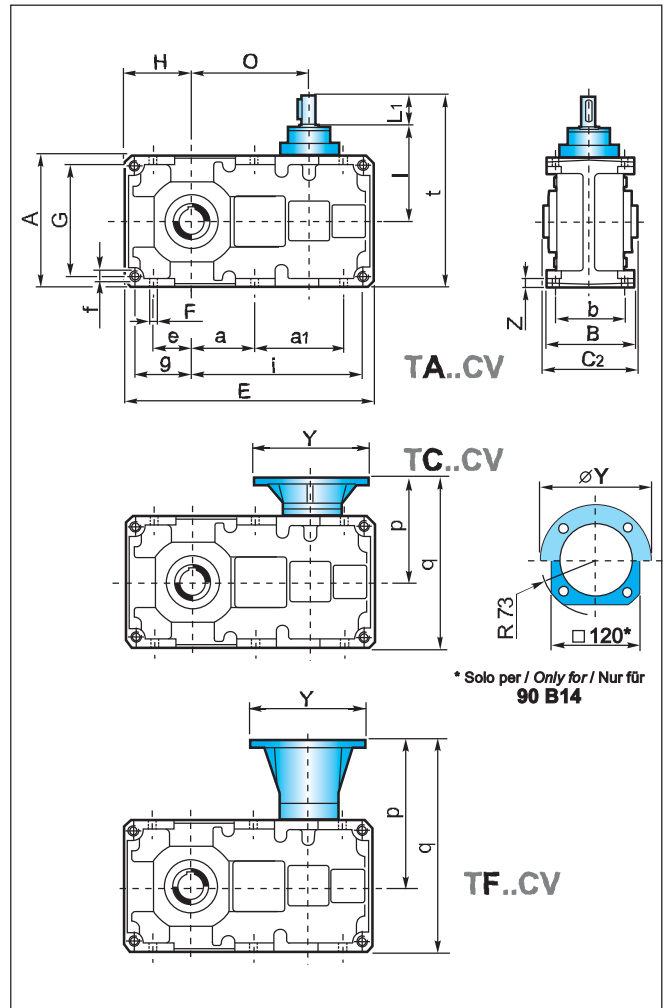

\* Solo per / Only for / Nur für  
90 B14

**Albero uscita cavo**  
**Hollow output shaft**  
**Abtriebshohlwelle**

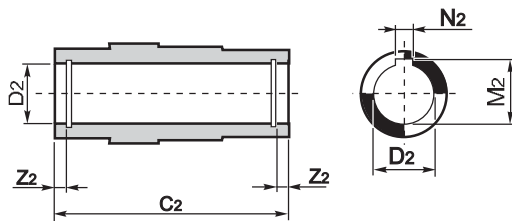

**Albero entrata**  
**Input shaft**  
**Antriebswelle**

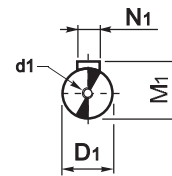

		TA... - TC... - TF...													
		80C			100C			125C		160C		180C		200C	
<b>D1 h6</b>		14			19			24		28		28		38	
<b>d1</b>		M4x15			M8x22			M8x22		M8x22		M8x22		M10x28	
<b>M1</b>		16			21.5			27		31		31		41	
<b>N1</b>		5			6			8		8		8		10	
<b>C2</b>		130			155			180		220		260		300	
<b>D2 H7</b>	<b>32</b>	30	35	<b>42</b>	40	45	<b>55</b>	50	<b>70</b>	60	<b>90</b>	80	<b>100</b>		
<b>M2</b>	35.3	33.3	38.3	45.3	43.3	48.8	59.3	53.8	74.9	64.4	95.4	85.4	106.4		
<b>N2</b>	10	8	10	12	12	14	16	14	20	18	25	22	28		
<b>Z2</b>	8.7	8.7	8.4	11	11	11	11.9	11.9	15.4	15.9	18.9	18.9	20		

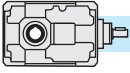

### 2.10 Accessori

### 2.10 Accessories

### 2.10 Zubehör

#### Albero lento

#### Output shaft

#### Abtriebswelle

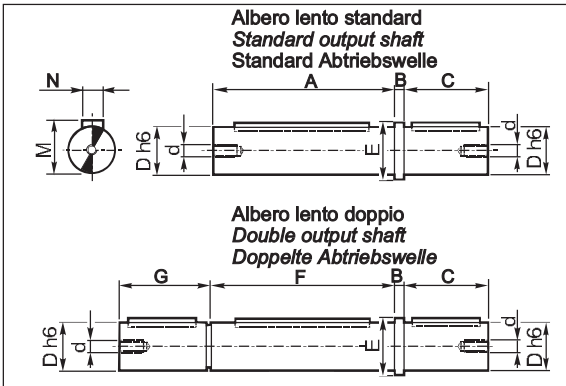

Materiale albero lento: EN 10083 - 1 C40 bonificato  
 Output shaft material: EN 10083 - 1 C40 tempered  
 Material der Abtriebswelle: EN 10083 - 1 C40 vergütet

	T										
	56B 56C	63B 63C	71B	90B 80C	112B 100C	140B 125C	180B 160C	200B 180C	225B 200C		
A	100	120	114	129	129	154	154	179	219	259	298
B	5	5	5	6	6	8	8	10	12	15	15
C	40	45	50	60	60	80	80	100	125	140	180
D <sub>h6</sub>	20	25	24	32	35	42	45	55	70	90	100
d	M8	M8	M8	M8	M8	M10	M10	M10	M12	M16	M18
E	26	32	30	40	43	50	53	65	80	110	118
F	100	120	115	130	—	155	—	180	220	260	300
G	41	46	49	59	—	79	—	99	124	141	178
M	22.5	28	27	35	38	45	48.5	59	74.5	94	106
N	6	8	8	10	10	12	14	16	20	25	28

#### Albero lento cavo con calettatore

#### Hollow output shaft with shrink disc

#### Abtriebshohlwelle mit Schrumpfscheibe

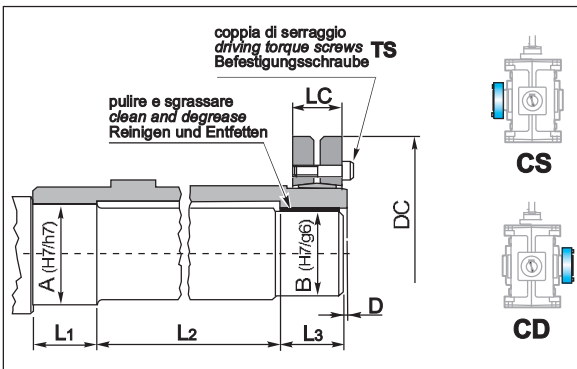

	T									
	56B 56C	63B 63C	71B	90B 80C	112B 100C	140B 125C	180B 160C	200B 180C	225B 200C	
A	27	32	27	37	47	57	72	92	102	
B	25	30	25	35	45	55	70	90	100	
D	2	2	2	2	2	2	2	3	3	
DC	60	72	60	80	100	115	155	188	215	
LC	21.5	23.5	22	26	31	31	39	50	54	
L <sub>1</sub>	32	36	36	39	45	50	60	70	80	
L <sub>2</sub>	61	75	68	82	100	115	143	175	200	
L <sub>3</sub>	32	36	36	39	45	50	60	70	80	
TS(Nm)	4	12	8	12	12	12	36	59	72	

#### Kit protezione albero cavo

#### Hollow shaft protection kit

#### Schutzvorrichtung für die Hohlwelle

Ad esclusione delle grandezze 56 e 63, a richiesta è possibile predisporre il riduttore con un kit di protezione dell'albero cavo. Tale protezione, essendo dotata di un'opportuna guarnizione, impedisce ad eventuali fluidi, presenti nell'ambiente di lavoro, di venire a contatto con l'albero cavo del riduttore oltre ad impedire il contatto con corpi estranei. Le dimensioni di ingombro sono riportate nella tabella seguente.

On request we can supply a hollow shaft protection kit (except for sizes 56 and 63). The kit features a gasket which prevents any contact between hollow shaft and foreign bodies or fluids existing in the working environment. Over-all dimensions are reported in the following table.

Auf Wunsch ist eine Schutzvorrichtung für die Hohlwelle lieferbar (Größen 56 und 63 ausgenommen). Die Schutzvorrichtung weist eine Dichtung auf, die zur Vermeidung von irgendwelchem Kontakt zwischen Hohlwelle und Fremdkörper oder Flüssigkeiten der Arbeitsumgebung dient. In der folgenden Tabelle wird den Raumbedarf angegeben.

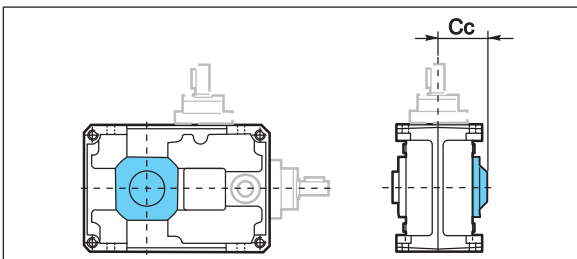

	T						
	71B	90B 80C	112B 100C	140B 125C	180B 160C	200B 180C	225B 200C
Cc	79.5	87	105	120.5	141.5	167.5	191.5

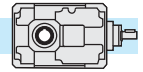

### Flangia uscita

### Output flange

### Abtriebsflansch

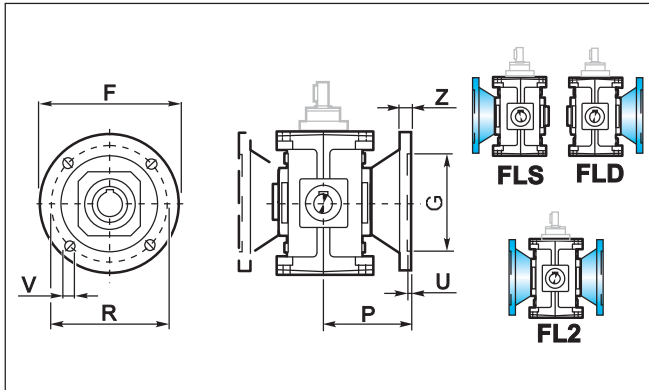

	T							
	56B 56C	63B 63C	71B	90B 80C	112B 100C	140B 125C	180B 160C	200B 180C
<b>F</b>	140	160	160	200	250	300	350	400
<b>G<sub>G6</sub></b>	95	110	110	130	180	230	250	300
<b>R</b>	115	130	130	165	215	265	300	350
<b>P</b>	82	91.5	87	100	125	150	180	215
<b>U</b>	5	5	4	4.5	5	5	6	6
<b>V</b>	9	9	12	12	14	16	18	20
<b>Z</b>	15	10	10	12	16	20	25	30
<b>kg</b>	0.5	0.5	2	3.2	5	8	12.5	24

### Braccio di reazione

### Torque arm

### Drehmomentstütze

#### 56B - 56C

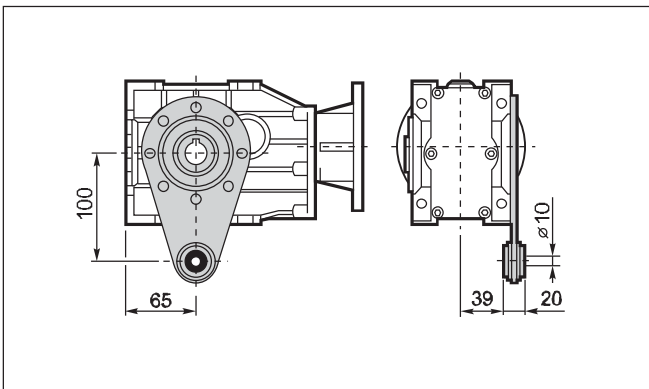

#### 63B - 63C

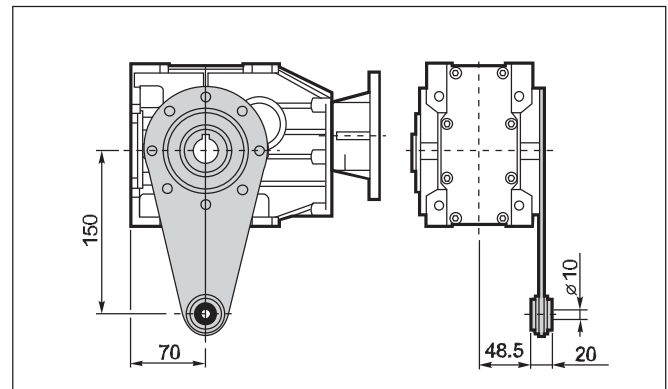

#### 71B - 225B

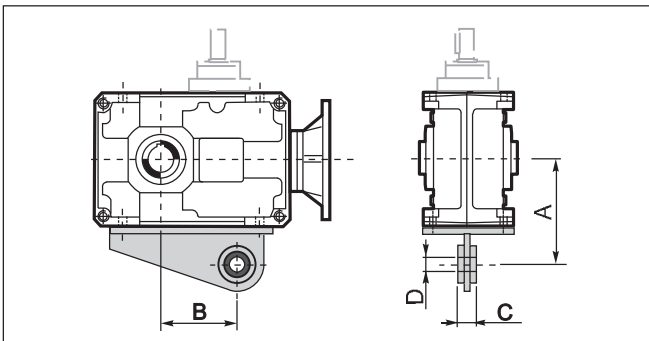

#### 80C - 200C

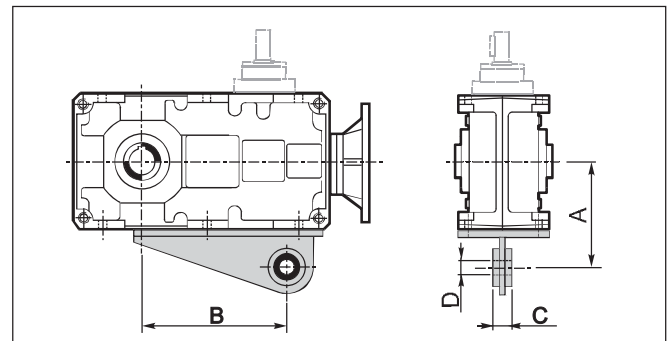

	T						
	71B	90B	112B	140B	180B	200B	225B
<b>A</b>	123	140	172	205	260	300	325
<b>B</b>	84	116	144	189	247.5	280	319
<b>C</b>	25	25	30	30	35	45	45
<b>D</b>	20	20	25	25	35	40	40

	T					
	80C	100C	125C	160C	180C	200C
<b>A</b>	130	160	190	240	280	300
<b>B</b>	170	214	276	354.5	367	456.5
<b>C</b>	25	30	30	35	45	45
<b>D</b>	20	25	25	35	40	40

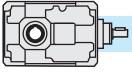

## Dispositivo antiritorno

Il riduttore ad assi ortogonali presenta valori di rendimento statico (e dinamico) molto elevati: per questo motivo non è garantita spontaneamente l'irreversibilità statica. L'irreversibilità statica si realizza quando, a riduttore fermo, l'applicazione di un carico all'albero lento non pone in rotazione l'asse entrato. Pertanto, per garantire l'irreversibilità del moto, a riduttore fermo, occorre predisporre il riduttore stesso con un opportuno dispositivo antiritorno, fornibile a richiesta tranne che sulle grandezze T56 e T63.

Tale dispositivo permette la rotazione dell'albero lento solo nel senso desiderato, da specificare all'atto dell'ordine.

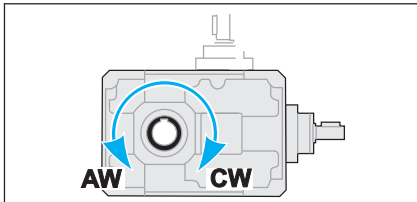

## Backstop device

*Bevel helical gearboxes feature quite high values of static (and dynamic) efficiency: for this reason spontaneous static irreversibility is not guaranteed. Static irreversibility, with motionless gearbox, occurs when the application of a load on the output shaft does not cause rotation of the input axis. In order to guarantee motion irreversibility, with motionless gearbox, it is necessary to fit a backstop device, which is available on request, except for sizes 56 and 63. The backstop device enables rotation of the output shaft only in the required direction, which is to be specified when ordering.*

## Rücklaufsperr

Kegelstirnradgetriebe weisen sehr hohen statischen (und dynamischen) Wirkungsgrad: deshalb wird keine spontane statische Irreversibilität garantiert. Statische Irreversibilität bei stillstehenden Getriebe hat man, wenn die Applikation einer Last auf die Abtriebswelle keine Drehung der Antriebswelle verursacht. Um Irreversibilität der Bewegung bei stillstehendem Getriebe zu sichern, soll eine Rücklaufsperr montiert werden. Die Rücklaufsperr wird auf Wunsch geliefert (Größen 56 und 63 ausgenommen).

Die Rücklaufsperr ermöglicht, dass die Abtriebswelle nur in der gewünschten Richtung dreht (gewünschte Richtung beim Bestellen angeben).

**CW** Rotazione oraria  
Clockwise rotation  
Im Uhrzeigersinn

**AW** Rotazione antioraria  
Anti-clockwise rotation  
Gegen den Uhrzeigersinn

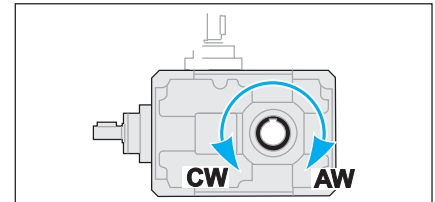

Un esempio tipico di applicazione in cui è richiesto l'impiego del dispositivo antiritorno è il caso in cui un riduttore venga utilizzato per la movimentazione di un nastro trasportatore inclinato, con il carico che si muove in salita. In caso di arresto dell'impianto, a causa del peso proprio del carico movimentato ed in assenza di sistemi di sicurezza, il nastro tenderebbe spontaneamente ad invertire il moto (moto retrogrado) riportando il materiale trasportato al punto di partenza. Il dispositivo antiritorno presente nel riduttore si oppone a questo fenomeno mantenendo il nastro fermo.

Nel caso in cui sia presente il dispositivo antiritorno è raccomandato l'utilizzo di olio lubrificante sintetico, classe di viscosità ISO 150.

*A typical example of application which requires a backstop device is when the gearbox is used for moving a sloping conveyor belt with the load moving upwards. In case the plant stops working, if there are no safety devices, because of the load weight the conveyor would tend to invert the motion direction (backward motion), thus bringing the transported material back to starting point. The backstop device on the gearbox prevents backward motion by keeping the conveyor motionless.*

*In gearboxes with backstop device we recommend synthetic lubricant, viscosity class ISO150.*

Ein typisches Beispiel von Anwendung der Rücklaufsperr ist, wenn das Getriebe für die Bewegung eines schiefen Förderbands benutzt wird, wobei die Last ansteigend bewegt wird. Im Falle von Stehenbleiben der Anlage und Abwesenheit von Sicherheitsvorrichtungen würde sich das Förderband spontan wegen des Lastgewichts rückwärts bewegen und das transportierte Material zurück zum Ausgangspunkt bringen. Die Rücklaufsperr hindert die Rückwärtsbewegung und hält das Förderband fest.

Beim Einsatz einer Rücklaufsperr ist die Verwendung von synthetischen Öl mit Viskositätsklasse ISO 150 empfohlen.

Nella tabella seguente (tab. 3) sono indicati i valori dei momenti torcenti nominali massimi ( $T_{2Mmax}$ ), riferiti all'albero uscita, garantiti dal dispositivo di antiritorno, per ogni rapporto di riduzione e per ogni grandezza di riduttore. Se, in corrispondenza dell'albero lento, viene applicata una coppia maggiore di quella indicata, l'irreversibilità del moto non è più garantita.

Questi valori di coppia non sono da confondere con quelli riportati nella tabella riguardante i dati tecnici dei riduttori.

Infatti, si noti come in tabella siano stati messi in evidenza i valori di coppia garantiti (in uscita) dal dispositivo antiretro che risultano essere minori dei massimi valori di coppia motrice trasmissibili, con fattore di servizio  $F_s = 1$ , dal riduttore.

*The following table (tab..3) shows the max. rated torques ( $T_{2Mmax}$ ) at gearbox output guaranteed by the backstop device, for each ratio and each gearbox size. If a higher torque is applied at gearbox output, motion irreversibility is no longer guaranteed.*

*These torque values are not to be confused with the values reported in the gearbox specifications tables.*

*Please note that the torque values guaranteed (at output) by the backstop device are lower than the max. driving torque values transmissible by the gearbox, with service factor  $F_s = 1$ .*

In der folgenden Tabelle (Tab. 3) werden die max. Nenndrehmomente am Abtrieb angegeben ( $T_{2Mmax}$ ), die die Rücklaufsperr je nach Untersetzungsverhältnis und Getriebegröße garantiert. Falls am Abtrieb ein höheres Drehmoment eingesetzt wird, dann ist die Irreversibilität der Bewegung nicht mehr garantiert.

Diese Drehmomente sind nicht mit den Werten zu verwechseln, den in der Tabelle der technischen Daten der Getriebe angegeben werden.

Die von Rücklaufsperr (am Abtrieb) garantierten Drehmomente sind niedriger als die von Getriebe übersetzbaren max. Drehmomente, unter Berücksichtigung eines Betriebsfaktors  $F_s = 1$ .

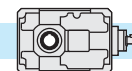

**Coppia massima garantita in uscita dal dispositivo antirritorno**  
*Max. output torque guaranteed by the backstop device*  
**Von Rücklaufsperrre garantierten max. Abtriebsdrehmoment**

Tab. 3

T	In													
	5*	6.3*	7*	8	10	12.5	16	20	25	31.5	40	50	63	80
	<b>T<sub>2M</sub> max [ Nm ]</b>													
71B	—	—	—	—	213	272	325	213	271	325	421	272	325	421
90B	148	204	—	—	333	424	508	333	424	508	657	424	508	657
112B	326	—	—	—	733	934	1118	733	933	1119	1446	933	1118	1446
140B	—	—	1038	—	1547	1969	2358	1547	1968	2359	3051	1968	2359	3050
180B	—	—	—	—	3009	3831	4588	3009	3829	4589	5935	3829	4589	5934
200B	—	—	—	5937	7607	9189	11399	12873	9190	11402	12875	11401	12875	—
225B	—	—	—	9856	11829	14538	9858	11838	14536	14537	17800	—	—	—

T	In												
	40	50	63	80	100	125	160	200	250	315	400	500	630
	<b>T<sub>2M</sub> max [ Nm ]</b>												
80C	—	1086	1301	1656	1086	1301	1656	1985	1301	1656	1985	2567	3319
100C	—	1697	2033	2588	1697	2033	2588	3101	2033	2588	3101	4010	5186
125C	—	3733	4474	5694	3733	4473	5693	6822	4473	5693	6822	8822	11410
160C	—	7874	9435	12008	7873	9435	12008	14388	9434	12008	14388	18607	24064
180C	—	7874	9435	12008	7873	9435	12008	14388	9434	12008	14388	18607	24064
200C	12511	15024	18453	22586	15023	18450	22594	15024	18452	22594	—	—	—

\* Rapporti speciali / *Special ratios* / Sonderverhältnisse

Valori di coppia garantiti / *Torque values guaranteed* / Garantierten Drehmomente

### Verifica del Dispositivo antirritorno

Dopo aver correttamente selezionato il riduttore (v. pag. 4), occorre verificare se il valore del momento torcente  $T_{2Mmax}$  garantito all'asse uscita del riduttore dal dispositivo antirritorno, considerate le reali condizioni di esercizio, è sufficiente a garantire il buon funzionamento dell'applicazione.

Deve pertanto essere verificata la seguente relazione:

### Check out of the backstop device

*After having selected the gearbox (see page 4) it is necessary to check whether the max. output torque  $T_{2Mmax}$  guaranteed by the backstop device, in view of the actual operating conditions, is sufficient to ensure the good functioning of the application.*

*The following equation has to be checked out:*

$$T_{2Mmax} = T_{2NOM} \cdot fc \cdot fa \cdot ft \quad (1)$$

### Prüfung der Rücklaufsperrre

Nach der Wahl des Getriebes (s. S. 4) soll es sichergestellt werden, dass das von der Rücklaufsperrre garantierte Abtriebsdrehmoment  $T_{2Mmax}$  genug ist, damit der korrekten Ablauf der Applikation unter Berücksichtigung der wirklichen Betriebsbedingungen gewährleistet wird.

Die folgende Relation ist festzustellen:

Dove:

$T_{2NOM}$  [Nm]: è il momento torcente che deve essere garantito all'asse uscita del riduttore, nell'istante in cui viene interrotta la trasmissione del moto, affinché sia soddisfatta la condizione di irreversibilità del moto.  $T_{2NOM}$  dipende dalle specifiche dell'applicazione e deve essere valutato volta per volta.

fc: fattore di carico

fc=1 in caso di funzionamento regolare  
 fc=1.3 in caso di funzionamento con urti moderati  
 fc=1.8 in caso di funzionamento con forti urti

Where:

$T_{2NOM}$  [Nm]: is the torque that must be guaranteed at gearbox output when motion transmission is stopped, in order that motion irreversibility is ensured.  $T_{2NOM}$  depends on application features and should be assessed each time.

fc: load factor

fc=1 in case of standard operation  
 fc=1.3 in case of operation with moderate shocks  
 fc=1.8 in case of operation with heavy shocks

Dabei ist:

$T_{2NOM}$  [Nm]: Drehmoment, das am Getriebebetrieb garantiert werden muss, wenn die Übertragung der Bewegung stoppt, damit Irreversibilität gewährleistet wird.  $T_{2NOM}$  hängt von der Merkmale der Applikation, d. h.  $T_{2NOM}$  muss jeweils bewertet werden.

fc: Last-Faktor

fc=1 bei Standardbetrieb  
 fc=1.3 bei Betrieb mit mäßigen Stößen  
 fc=1.8 bei Betrieb mit starken Stößen

#### NOTA:

Per funzionamento regolare si intende il caso in cui il dispositivo antirritorno, in attesa della ripresa della normale attività del riduttore, mantiene la macchina ferma. Se invece, nel momento in cui il dispositivo antirritorno è azionato (quindi il riduttore è fermo), il carico in uscita aumenta di intensità si possono avere degli urti (moderati o forti).

#### REMARK:

standard operation means that the backstop device keeps the machine still, whilst awaiting the restart of gearbox operation. On the contrary, in case the backstop device is enabled (therefore the gearbox is motionless) and the output load gets heavier, moderate or heavy shocks might occur.

#### ANMERKUNG:

Standardbetrieb bedeutet, dass (in Erwartung des Wiederbeginns des Getriebebetriebs) die Rücklaufsperrre die Maschine stoppt. Dagegen, falls die Rücklaufsperrre betätigt ist (deshalb bewegt sich das Getriebe nicht) und die Last am Abtrieb stärker wird, dann können mäßigen oder starken Stößen entstehen.

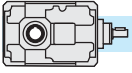

**fa:** fattore di applicazione, ricavabile dalla seguente tabella (tab. 4) in funzione del numero di inserzioni/ora e dal numero di ore di funzionamento al giorno del riduttore.

**fa:** application factor, as shown in the following table (tab. 4), depending on the number of backstop device insertions per hour and the number of gearbox operating hours per day.

**fa:** Anwendungsfaktor, wie es in der folgenden Tabelle (tab. 4) angegeben wird. Der Anwendungsfaktor hängt von Zahl der Einschaltungen der Rücklaufsperrung pro Stunde und von Betriebsstunden des Getriebes pro Tag ab.

Tab. 4

h/gg - h/d - St./Tag	n° INSERZIONI / h - INSERTIONS / H - NR. EINSCHALTUNGEN / STUNDE					
	2	4	8	16	32	63
8	1	1	1.1	1.2	1.3	1.4
16	1.3	1.3	1.4	1.5	1.6	1.7
24	1.5	1.5	1.6	1.7	1.8	1.9

**ft:** fattore di temperatura ricavabile dalla seguente tabella (tab.5) in funzione della temperatura ambiente di funzionamento.

**ft:** temperature factor, as shown in the following table (tab. 5) depending on ambient temperature during gearbox operation.

**ft:** Temperaturfaktor, wie es in der folgenden Tabelle (tab. 5) angegeben wird. Der Temperaturfaktor hängt von der Umgebungstemperatur während Getriebebetriebs ab.

Tab. 5

Tamb (°C)	-20°	-10°	0°	10°	20°	30°	40°	50°
ft	1.2	1.15	1.1	1.05	1	1.03	1.05	1.10

Se la relazione (1) a pag. 25 non risulta essere verificata si prenda in considerazione la possibilità o di variare il rapporto di riduzione, individuando una alternativa migliore, o di passare alle grandezze di riduttori successive.

If the result of the calculation does not correspond to the equation (1) at page 25, either the ratio has to be modified or a bigger size of gearbox has to be selected.

Falls das Resultat nicht der Relation (1) entspricht (Seite 25), soll entweder das Untersetzungsverhältnis oder die Größe des Getriebes geändert werden.

Nel caso in cui il riduttore, provvisto di dispositivo antiritorno, si trovi ad operare ad una temperatura ambiente minore di 0°C il riduttore può essere fornito, a seconda del rapporto di riduzione, in esecuzione speciale (con camera stagna) così da migliorare il funzionamento del dispositivo. Per quanto riguarda quest'ultima soluzione si contatti il servizio tecnico Tramec.

If the ambient temperature is below 0°C, the gearbox with backstop device can be supplied in the special execution (with tight chamber) which improves the functioning of the backstop device. Please contact Tramec Technical Dept. for further information.

Liegt die Umgebungstemperatur unter 0°C, wird es empfohlen, die Sonderausführung des Getriebes (mit Dichtkammer) zu benutzen, damit die Rücklaufsperrung am besten funktioniert. Für weitere Auskünfte darüber soll man sich mit Tramec technischen Büro in Verbindung setzen.

Dimensioni riferite alla versione con antiretro

Dimensions of the version with backstop device

Abmessungen der Version mit Rücklaufsperrung

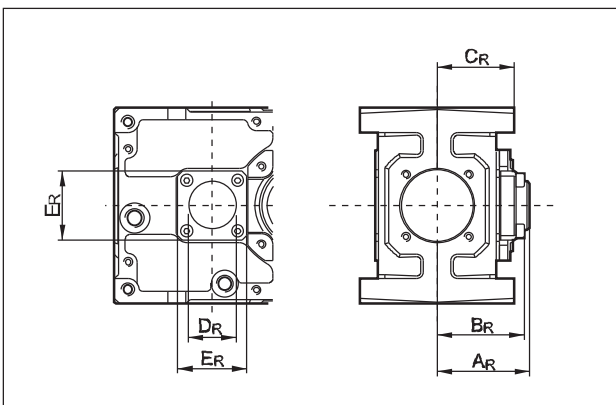

	AR	BR	CR	DR	ER
T 71B	67	63	56	35	50
T 80C	67	63	63.5	45	60
T 90B	73	68	63.5	45	60
T 100C	71.5	70	75	55	80
T 112B	90	83	75	55	80
T 125C	86.5	96.5	87.5	60	90
T 140B	108	95	87.5	70	90
T 160C	106.5	101	107.5	70	100
T 180B	122	113	107.5	80	110
T180C	110.5	110	127.5	70	100
T200B	163	137.5	127.5	90	160
T 200C	125	124	145	90	130
T 225B	169	147	145	110	155

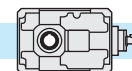

## 2.11 Giochi angolari

Bloccando l'albero di entrata, il gioco viene misurato sull'albero uscita ruotandolo nelle due direzioni ad applicando la coppia strettamente necessaria a creare il contatto tra i denti degli ingranaggi, al massimo pari al 2% della coppia massima garantita dal riduttore ( $T_{2M}$ ).

Nella tabella seguente sono riportati i valori indicativi del gioco angolare (in minuti di angolo) per quanto riguarda il montaggio normale ed i valori ottenibili con una registrazione più precisa. Quest'ultima esecuzione è da utilizzare solo in caso di reale necessità in quanto potrebbe comportare un leggero aumento della rumorosità e rendere meno efficace l'azione dell'olio lubrificante.

## 2.11 Angular backlash

*After having blocked the input shaft, the angular backlash can be measured on the output shaft by rotating it in both directions and applying the torque which is strictly necessary to create a contact between the teeth of the gears. The applied torque should be at most 2% of the max. torque guaranteed by the gearbox. ( $T_{2M}$ ).*

*The following table reports the approximate values of the angular backlash (in minutes of arc) referred to standard mounting and mounting with a more precise adjustment. The latter solution should be adopted only in case of necessity because it may raise the noise level and lessen the action of the lubricant.*

## 2.11 Winkelspiel

Nachdem die Antriebswelle blockiert worden ist, darf das Winkelspiel auf die Abtriebswelle bemessen werden. Dabei soll die Abtriebswelle in beiden Richtungen gedreht werden und ein Drehmoment ausgeübt werden, das zur Entzerrung eines Kontaktes zwischen den Zähnen genügt. Das ausgeübte Drehmoment soll höchstens 2% des max. von Getrieben garantierten Drehmoment ( $T_{2M}$ ) sein.

Die folgende Tabelle weist die Näherungswerte des Winkelspiels (in Bogenminuten) für Standardmontage und Montage mit präziser Regulierung. Die präzisere Lösung darf nur im Notfall angewendet werden, weil infolgedessen das Geräuschpegel zunimmt und die Wirkung des Schmiermittels abnimmt.

Gioco angolare / Backlash / Winkelspiel (1')		
	Montaggio normale Standard mounting Standardmontage	Montaggio con gioco ridotto Mounting with reduced backlash Montage mit reduziertem Winkelspiel
2 stadi/stages/stufig	16/20	12/15
3 stadi/stages/stufig	20/25	15/17

## 2.12 Lubrificazione

I riduttori ad assi ortogonali (ad esclusione dei tipi TF56 e TF63, con lubrificazione a vita) sono forniti predisposti per lubrificazione a olio e muniti dei tappi di carico, livello e scarico olio.

Si raccomanda di precisare sempre la posizione di montaggio desiderata in fase di ordine.

### POMPA DI LUBRIFICAZIONE.

Una pompa per lubrificazione forzata dei cuscinetti superiori è fornita a richiesta sulle grandezze 112, 125, 140, 160, 180, 200 e 225 nella posizione di montaggio VA.

Nelle posizioni di montaggio in cui sono presenti cuscinetti posti al di sopra del livello dell'olio lubrificante è prevista l'applicazione di grasso speciale su tali cuscinetti per migliorarne la lubrificazione. E' possibile dotare gli stessi cuscinetti di un anello metallico (nylos) con la funzione di contenimento del grasso e, di conseguenza, di prolungare l'effetto nel tempo. Questa soluzione viene fornita su specifica richiesta.

## 2.12 Lubrication

*Bevel helical gearboxes (except for TF56 and TF63 which are lubricated for life) require oil lubrication and are equipped with filler, level and drain plugs.*

*The mounting position should always be specified when ordering the gearbox.*

### OIL PUMP.

*A pump for forced lubrication of the upper bearings is supplied on request for sizes 112, 125, 140, 160, 180, 200 and 225 in the VA mounting position.*

*Depending on the mounting position, the bearings may be lodged above the lubricant level. In this case it is necessary to apply special grease on the bearings in order to improve their lubrication. A metallic ring (nylos) can be fitted on the bearings it keeps the grease in place thus prolonging the action. It is supplied on specific request.*

## 2.12 Schmierung

Die Kegelstirradgetriebe sind für die Ölschmierung mit Einfüll-, Ölstand- und Ablassstopfen versehen.

Bei der Bestellung ist immer die gewünschte Montageposition anzugeben.

### ÖLPUMPE.

Eine Pumpe für die Zwangsschmierung der oberen Lager kann auf Wunsch bei den Größen 112, 125, 140, 160, 180, 200 und 225 in der Montageposition VA geliefert werden.

Abhängig von der Einbaulage kann es sein, dass die Lager über den Ölstand liegen. In dem Fall wird Sonderfett auf die Lager geschmiert, um deren Schmierung zu verbessern. Ein metallischer Ring (nylos) für die Lager darf auf Wunsch geliefert werden: er hält das Fett fest und verlängert die Wirkung.

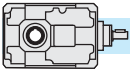

**Posizione di montaggio e quantità di lubrificante (litri)**

I quantitativi di olio riportati nelle varie tabelle sono indicativi e riferiti alle posizioni di lavoro indicate e considerando le condizioni di funzionamento a temperatura ambiente e velocità in ingresso di 1400 min<sup>-1</sup>. Per condizioni di lavoro diverse da quelle sopra riportate contattare il servizio tecnico.

**Mounting positions and lubricant quantity (liters)**

The oil quantities stated in the tables are approximate values and refer to the indicated working positions, considering operating conditions at ambient temperature and an input speed of 1400 min<sup>-1</sup>. Should the operating conditions be different, please contact the technical service.

**Montageposition und Ölmenge (liter)**

Die in der Tabellen angegebenen Daten sind Richtwerte. Die Ölmenge beziehen sich auf die angegebenen Betriebsposition. Dabei werden Betrieb bei Umgebungstemperatur und Antriebsdrehzahl von 1400 min<sup>-1</sup> berücksichtigt. Falls die Betriebsbedingungen anders sind, dann ist das technische Büro zu befragen.

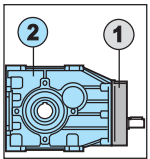
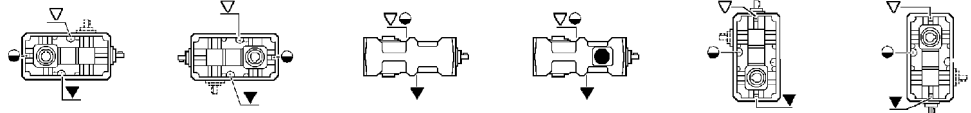

T	B3	B8	B6	B7	VA	VB
② 56B			0.30		0.40	0.30
① 56C				0.05		
② 56C		0.30			0.40	0.30
② 63B		0.35			0.45	0.35
① 63C				0.05		
② 63C		0.35			0.45	0.35
71B	0.6		0.7	0.5		0.8
80C	1.1		1.5	1.3		1.5
90B	1.0		1.4	1.2		1.3
100C	2.0		2.6	2.3		2.8
112B	1.8		2.6	2.3		2.4
125C	3.8		4.8	4.5		5.0
140B	3.6		4.6	4.3		4.3
160C	7.0		9.2	8.7		10.0
180B	7.5		9.7	9.2		8.0
180C	9.5		14.0	13.0		15.5
200B	12.5		15.0	14.0		17.5
200C	13.5		19.0	18.0		19.5
225B	14.5		19.0	18.0		18.7

- \* Nella posizione di montaggio B6 è previsto un tappo di sfiato con asta di livello.
- \* In mounting position B6 the breather plug is fitted with dipstick.
- \* Für die B6 Version ist eine Entlüftungsschraube mit Ölstandsanzeiger vorausgesehen.

**Posizione morsetti**

**Terminal board position**

**Lage der Klemmenkaste**

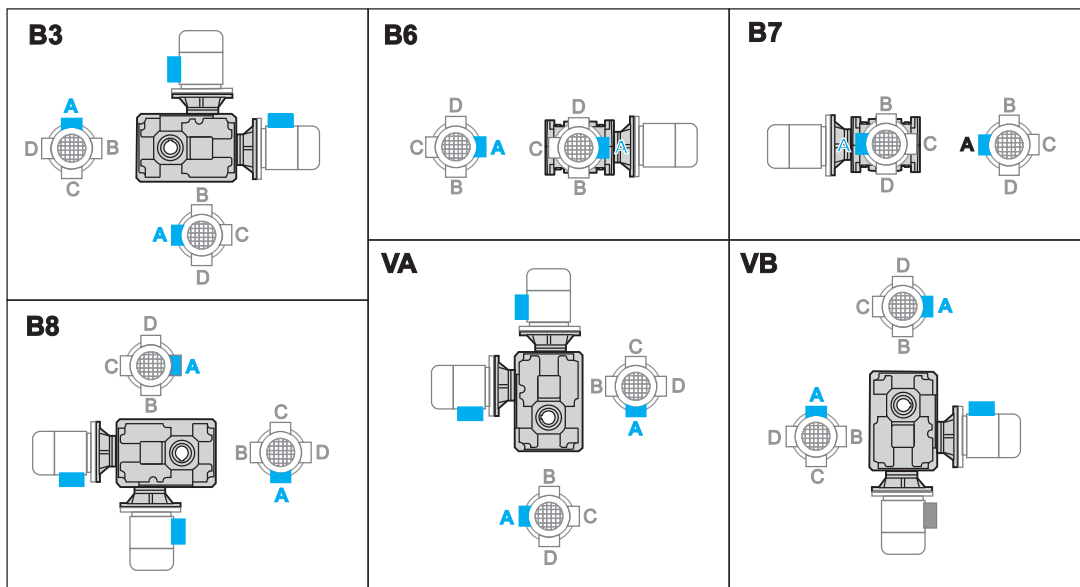

N.B.  
Se non diversamente specificato, il motore verrà fornito con la morsetti in posizione A.

N.B.  
Unless otherwise agreed, the motor will be supplied with the terminal board in position A.

ANMERKUNG:  
Ausser wenn anders angegeben, wird der Motor mit Klemmenkaste in der A Position geliefert.

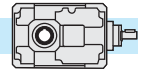

### 2.13 Carichi radiali e assiali (N)

Le trasmissioni effettuate tramite pignoni per catena, ruote dentate o pulegge generano delle forze radiali ( $F_R$ ) sugli alberi dei riduttori. L'entità di tali forze può essere calcolata con la formula:

### 2.13 Radial and axial loads (N)

Transmissions implemented by means of chain pinions, wheels or pulleys generate radial forces ( $F_R$ ) on the gear unit shafts. The entity of these forces may be calculated using the following formula:

### 2.13 Radial- und Axialbelastungen (N)

Antriebe mit Kettenritzel, Zahnradern oder Riemenscheiben erzeugen radiale Kräfte ( $F_R$ ) an den Wellen der Untersetzungsgetriebe. Das Ausmaß dieser Kräfte kann nach folgender Formel berechnet werden:

$$F_R = \frac{K_R \cdot T}{d} \text{ [N]}$$

dove:

T = Momento torcente [Nm]  
d = Diametro pignone o puleggia [mm]  
 $K_R$  = 2000 per pignone per catena  
= 2500 per ruote dentate  
= 3000 per puleggia con cinghie a V

where :

T = torque [Nm]  
d = pinion or pulley diameter [mm]  
 $K_R$  = 2000 for chain pinion  
= 2500 for wheel  
= 3000 for V-belt pulley

dabei ist:

T = Drehmoment [Nm]  
d = Kettenritzel- bzw. Riemenscheibendurchmesser [mm]  
 $K_R$  = 2000 bei Kettenritzel  
= 2500 bei Zahnrad  
= 3000 bei Riemenscheibe mit Keilriemen

I valori dei carichi radiali e assiali generati dall'applicazione debbono essere sempre minori o uguali a quelli ammissibili indicati nelle tabelle.

The values of the radial and axial loads generated by the application must always be lower than or equal to the admissible values reported in the tables.

Die Werte der Radial- und Axialbelastungen, die durch die Anwendung hervorgerufen werden, dürfen nicht über den in den Tabellen angegebenen zulässigen Werten liegen.

$$F_R \leq F_{R1-2}$$

Se il carico radiale sull'albero non è applicato a metà della sporgenza dell'albero, il valore del carico ammissibile deve essere valutato utilizzando la formula che si riferisce ad  $F_{Ry1-2}$ , in cui i valori di a, b e  $F_{R1-2}$  sono riportati nelle tabelle relative ai carichi radiali.

Nel caso di alberi bisporgenti il valore del carico applicabile a ciascuna estremità è uguale ai 2/3 del valore di tabella, purchè i carichi applicati siano uguali di intensità e direzione ed agiscano nello stesso senso. Diversamente contattare il servizio tecnico.

Should the radial load affect the shaft not at the half-way point of its projection but at a different point, the value of the admissible load has to be calculated using the  $F_{Ry1-2}$  formula: a, b and  $F_{R1-2}$  values are reported in the radial load tables.

With regard to double-projecting shafts, the load applicable at each end is 2/3 of the value given in the table, on condition that the applied loads feature same intensity and direction and that they act in the same direction.

Otherwise please contact the technical department.

Falls die Radialbelastungen nicht in dem Mittelpunkt der herausragenden Welle sondern in einem anderen Punkt wirken, soll die zulässige Belastung mit der Formel bezüglich  $F_{Ry1-2}$  kalkuliert werden: a, b und  $F_{R1-2}$  Werte sind aus der Tabelle der Radialbelastungen zu entnehmen.

Bei zweifach vorstehenden Wellen ist die Belastung, die an jede Ende anwendbar ist, 2/3 des in der Tabelle angegebenen Wertes unter der Bedingung, dass die Belastungen die selbe Stärke und Richtung aufweisen und dass sie in der selben Richtung wirken. Andernfalls ist das technische Büro zu befragen.

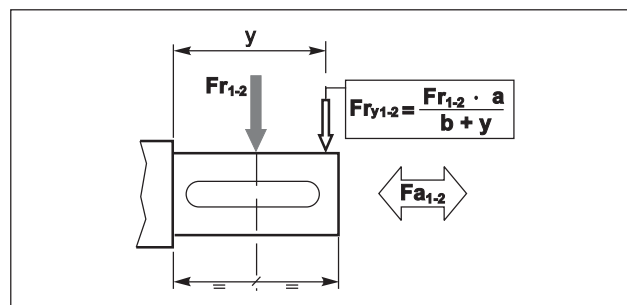

I carichi radiali indicati nelle tabelle si intendono applicati a metà della sporgenza dell'albero e sono riferiti ai riduttori operanti con fattore di servizio 1.

The radial loads indicated in the chart are considered to be applied at the half-way point of the shaft projection, and refer to gear units operating with service factor 1.

Die in den Tabellen angegebenen radialbelastungen gelten für Ansatzpunkte in der Mitte des herausragenden Wellenteils und für Getriebe mit Betriebsfaktor 1.

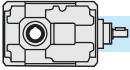

		T 56B		T 63B				T 56C		T 63C	
		a=102	b=82	a=117	b=94.5			a=102	b=82	a=117	b=94.5
<b>ALBERO ENTRATA / INPUT SHAFT / ANTRIEBSWELLE (n<sub>1</sub> = 1400 min<sup>-1</sup>)</b>											
in		Fr <sub>1</sub>	Fa <sub>1</sub>	Fr <sub>1</sub>	Fa <sub>1</sub>	in		Fr <sub>1</sub>	Fa <sub>1</sub>	Fr <sub>1</sub>	Fa <sub>1</sub>
<b>Tutti All Alle</b>		*	*	*	*	<b>Tutti All Alle</b>		*	*	*	*

\* Consultare il ns. Servizio Tecnico.

\* Contact Tramec Technical dept..

\* Fragen sie Tramec technisches Büro.

		T 56B		T 63B				T 56C		T 63C	
		a=102	b=82	a=117	b=94.5			a=102	b=82	a=117	b=94.5
<b>ALBERO USCITA / OUTPUT SHAFT / ABTRIEBSWELLE (n<sub>1</sub> = 1400 min<sup>-1</sup>)</b>											
in		Fr <sub>2</sub>	Fa <sub>2</sub>	Fr <sub>2</sub>	Fa <sub>2</sub>	in		Fr <sub>2</sub>	Fa <sub>2</sub>	Fr <sub>2</sub>	Fa <sub>2</sub>
<b>8</b>		1300	260	1500	300	<b>40</b>		2300	460	2500	500
<b>10</b>		1300	260	1500	300	<b>50</b>		2300	460	2500	500
<b>12.5</b>		1300	260	1500	300	<b>63</b>		2300	460	2500	500
<b>16</b>		1800	360	2000	400	<b>80</b>		2800	560	3000	600
<b>20</b>		1800	360	2000	400	<b>100</b>		2800	560	3000	600
<b>25</b>		1800	360	2000	400	<b>125</b>		2800	560	3000	600
<b>31.5</b>		1800	360	2000	400	<b>160</b>		2800	560	3000	600
<b>40</b>		2300	460	2500	500	<b>200</b>		3000	600	3500	700
<b>50</b>		2300	460	2500	500	<b>250</b>		3000	600	3500	700
<b>63</b>		—	—	2500	500	<b>315</b>		—	—	3500	700

		T 71B		T 90B		T 112B		T 140B		T 180B		T200B		T 225B	
		a=114.5	b=84.5	a=127.5	b=95.5	a=161.5	b=113.5	a=192	b=132	a=237	b=162	a=276	b=191	a=326	b=221
<b>ALBERO ENTRATA / INPUT SHAFT / ANTRIEBSWELLE (n<sub>1</sub> = 1400 min<sup>-1</sup>)</b>															
in		Fr <sub>1</sub>	Fa <sub>1</sub>	Fr <sub>1</sub>	Fa <sub>1</sub>	Fr <sub>1</sub>	Fa <sub>1</sub>	Fr <sub>1</sub>	Fa <sub>1</sub>	Fr <sub>1</sub>	Fa <sub>1</sub>	Fr <sub>1</sub>	Fa <sub>1</sub>	Fr <sub>1</sub>	Fa <sub>1</sub>
<b>8-40</b>		400	80	630	125	1000	200	1600	320	2500	500	2500	500	3150	630
<b>50÷ 80</b>										2000	400	2000	400		
<b>ALBERO USCITA / OUTPUT SHAFT / ABTRIEBSWELLE (n<sub>1</sub> = 1400 min<sup>-1</sup>)</b>															
in		Fr <sub>2</sub>	Fa <sub>2</sub>	Fr <sub>2</sub>	Fa <sub>2</sub>	Fr <sub>2</sub>	Fa <sub>2</sub>	Fr <sub>2</sub>	Fa <sub>2</sub>	Fr <sub>2</sub>	Fa <sub>2</sub>	Fr <sub>2</sub>	Fa <sub>2</sub>	Fr <sub>2</sub>	Fa <sub>2</sub>
<b>≤ 8</b>		—	—	—	—	—	—	—	—	—	—	25000	5000	36000	7200
<b>10</b>		3000	600	4750	950	7500	1500	11800	2360	19000	3800	26800	5360	38000	7600
<b>12.5</b>		3150	630	5000	1000	8000	1600	12500	2500	20000	4000	28800	5760	40000	8000
<b>16</b>		3350	670	5300	1060	8500	1700	13200	2640	21200	4240	30400	6080	42400	8480
<b>20</b>		3550	710	5600	1120	9000	1800	14000	2800	22400	4480	32200	6440	44800	8960
<b>25</b>		3750	750	6000	1200	9500	1900	15000	3000	23600	4720	34000	6800	47200	9440
<b>31.5</b>		4000	800	6300	1260	10000	2000	16000	3200	25000	5000	35800	7160	50000	10000
<b>40</b>		4250	850	6700	1340	10600	2120	17000	3400	26500	5300	37600	7520	53000	10600
<b>50</b>		4500	900	7100	1420	11200	2240	18000	3600	28000	5600	41200	8240	—	—
<b>63</b>		4750	950	7500	1500	11800	2360	19000	3800	30000	6000	43000	8600		
<b>80</b>		5000	1000	8000	1600	12500	2500	20000	4000	32000	6400	—	—		

		T 80C		T 100C		T 125C		T 160C		T180C		T 200C	
		a=127.5	b=95.5	a=161.5	b=113.5	a=192	b=132	a=237	b=162	a=276	b=191	a=326	b=221
<b>ALBERO ENTRATA / INPUT SHAFT / ANTRIEBSWELLE (n<sub>1</sub> = 1400 min<sup>-1</sup>)</b>													
in		Fr <sub>1</sub>	Fa <sub>1</sub>	Fr <sub>1</sub>	Fa <sub>1</sub>	Fr <sub>1</sub>	Fa <sub>1</sub>	Fr <sub>1</sub>	Fa <sub>1</sub>	Fr <sub>1</sub>	Fa <sub>1</sub>	Fr <sub>1</sub>	Fa <sub>1</sub>
<b>Tutti All Alle</b>		400	80	630	125	1000	200	1600	320	2000	400	2500	500
<b>ALBERO USCITA / OUTPUT SHAFT / ABTRIEBSWELLE (n<sub>1</sub> = 1400 min<sup>-1</sup>)</b>													
in		Fr <sub>2</sub>	Fa <sub>2</sub>	Fr <sub>2</sub>	Fa <sub>2</sub>	Fr <sub>2</sub>	Fa <sub>2</sub>	Fr <sub>2</sub>	Fa <sub>2</sub>	Fr <sub>2</sub>	Fa <sub>2</sub>	Fr <sub>2</sub>	Fa <sub>2</sub>
<b>Tutti All Alle</b>		8000	1600	12500	2500	20000	4000	32000	6400	43000	8600	53000	10600





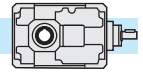

**TA..B - TC..B - TF..B**

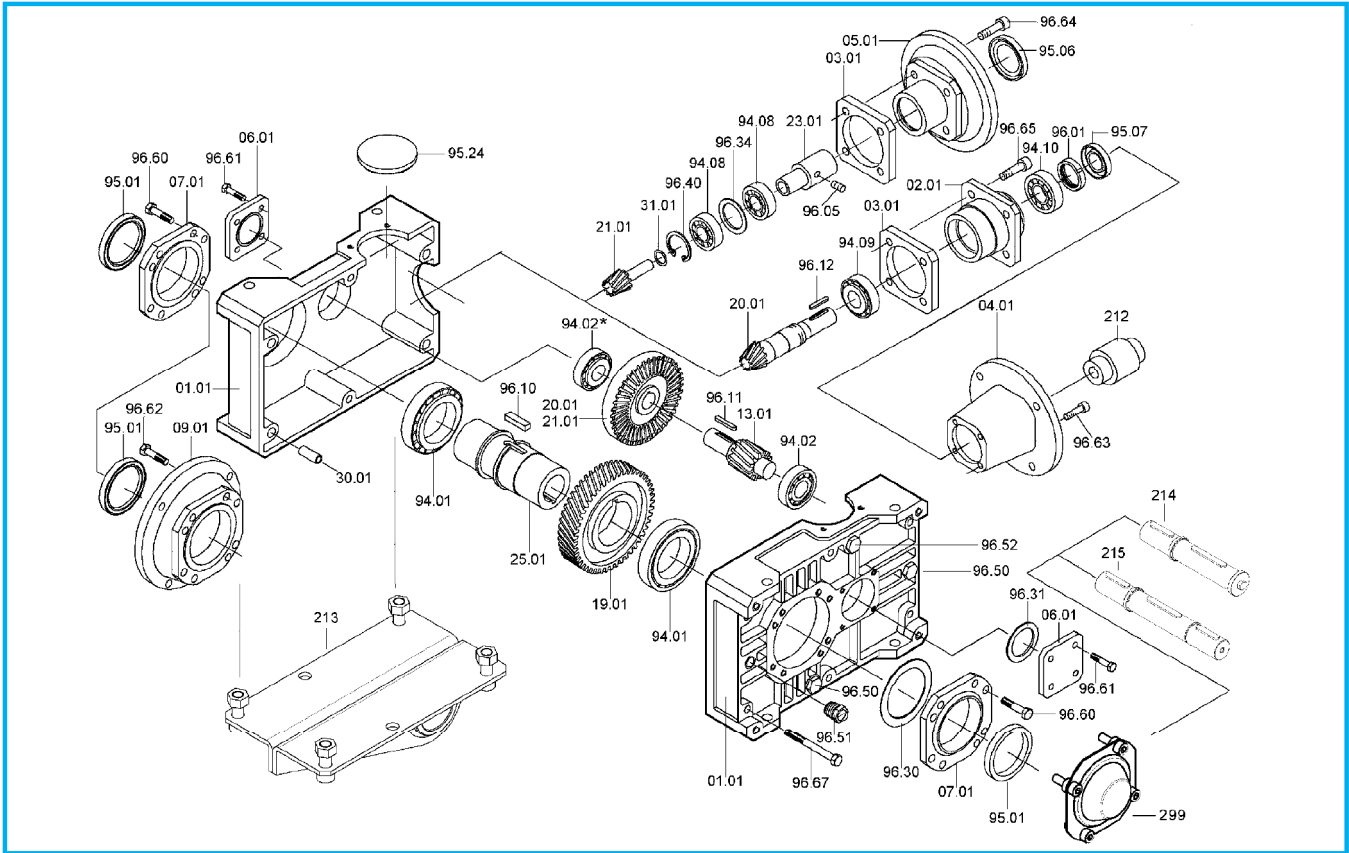

T	Cuscinetti / Bearings / Lager				Anelli di tenuta / Oilseals / Öldichtungen				
	TA - TC - TF	TC	TA - TF	TA - TC - TF	TC	TA - TF			
	94.01	94.02	94.08	94.09	94.10	95.01	IEC	95.06	95.07
<b>71B</b>	32008 40/68/19	30302 15/42/14.25	7203 17/40/12	30203 17/40/13.25	40/56/8	63	25/52/7	15/40/10	
							71		30/52/7
							80		35/52/7
							90		37/52/8
<b>90B</b>	32010 50/80/20	30204 20/47/15.25	7205 25/52/15	32005 25/47/15	50/65/8	71 - 80	35/62/7	20/47/7	
						90	40/62/7		
						100 - 112	45/62/8		
<b>112B</b>	32012 60/95/23	30305 25/62/18.25	7206 30/62/16	32006 30/55/17	60/80/10	80 - 90	40/72/7	25/58/10	
						100 - 112	45/72/8		
						132	55/72/10		
						80 - 90	45/80/10		
<b>140B</b>	32015 75/115/25	32206B 30/62/21.25	7207 35/72/17	32007 35/62/18	75/95/10	100 - 112	45/80/10	30/62/7	
						100 - 112	45/80/10		
						132	55/80/10		
						160	60/80/8		
						180	65/80/8		
<b>180B</b>	32019 95/145/32	31307 / (32208)* 35/80/22.75 / (40/80/24.75)*	7209 45/85/19	32009 45/75/20	95/125/12	100 - 112	55/100/13	40/80/10	
						132 - 160	60/100/10		
						180	65/100/10		
						200	75/100/10		
<b>200B</b>	32024 120/180/38	31309 45/100/27.25	7209 45/85/19	33109 45/80/26	120/160/15	100 - 112	55/100/13	40/80/10	
						132 - 160	60/100/10		
						180	65/100/10		
						200	75/100/10		
<b>225B</b>	32026 130/200/45	31310 50/110/29.25	—	33111 55/95/30	32011 55/90/23	130/160/12	—	—	50/90/10

\* Presente solo nella versione con antiretro / Only on version with back stop device / Nur auf Version mit Rücklaufperre



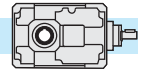

## TA..B - TC..B - TF..B - TA..C - TC..C - TF..C

### Dispositivo antiritorno - Backstop device - Rücklaufsperr

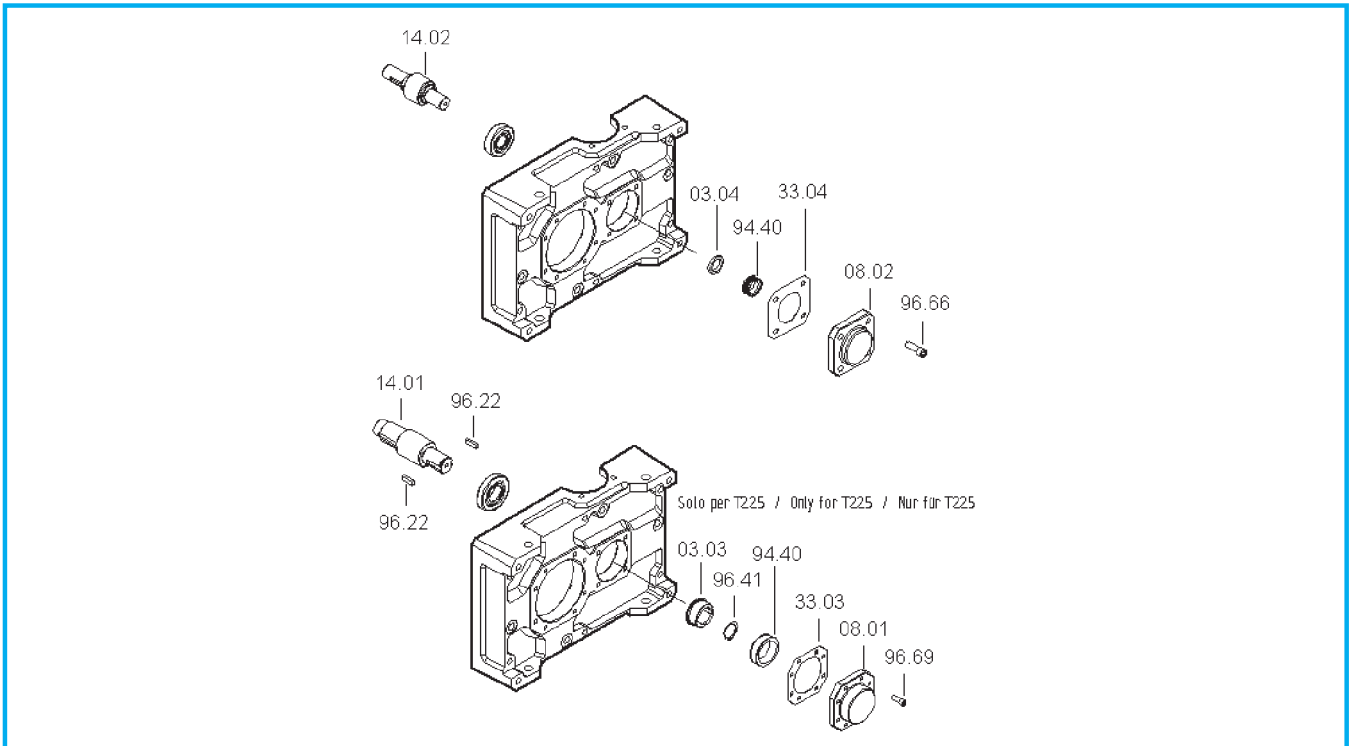

T...B	Ruota libera / Free wheel / Freilauftrad 94.40
71	FE 423 Z
90	FE 428 Z
112	BF 50 Z 16
140	BF 70 Z 21
180	FE 8040 Z 19
200	FE 8054 Z 25
225	FE 8072 Z 25

T...C	Ruota libera / Free wheel / Freilauftrad 94.40
80	FE 423 Z
100	FE 428 Z
125	BF 50 Z 16
160	BF 70 Z 21
180	BF 70 Z 21
200	FE 8040 Z 19

In fase di ordine delle parti di ricambio, specificare sempre n° particolare (vedi disegno esploso), data (1), n° codice (2) e n° variante (3).  
(Vedi targhetta).

When ordering a spare part, the spare part number (see exploded technical drawing), the date (1), the code number (2) and the variant number (3) should always be reported.  
(See plate)

Bei der Bestellung von Ersatzteilen sind Ersatzteilnummer (s. Explosionszeichnung), Datum (1), Artikelnummer (2) und Variantennummer (3) anzugeben.  
(s. Schild)

